



INSTALLATION GUIDE

BRONCO 4-DOOR ROCKER GUARDS



HARDWARE

ITEMS	QTY
ROCKER GUARD	2
TREAD PLATE	2
TREAD PLATE HARDWARE	
1/4" – 20 X 3/4" Button Head Bolt	35
1/4" – 20 Nyloc Nut	35
ROCKER GUARD HARDWARE	
5/16" – 18 X 1" Hex Cap Bolt	12
5/16" – 18 Nyloc Nut	12
5/16" USS Washer	24
M10 – 1.5 X 40mm Hex Cap Bolt	8
3/8" USS Washer	8

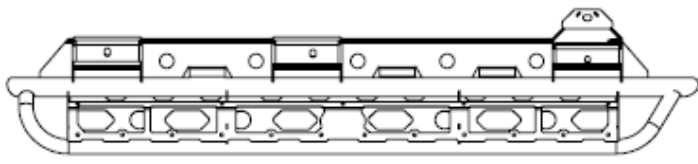
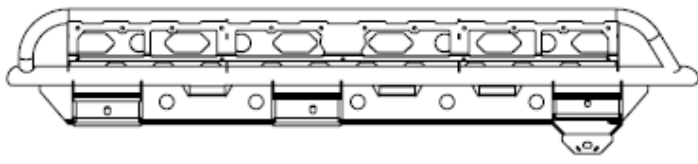

SKILL LEVEL - 2 STARS



- 1 STAR ★☆☆☆☆
- 2 STARS ★★☆☆☆
- 3 STARS ★★★☆☆
- 4 STARS ★★★★☆
- 5 STARS ★★★★★

- EASY - No tools required
- BASIC - Requires standard tools, basic mechanical knowledge and understanding
- MODERATE - Requires standard tools. Some drilling and/or cutting.
- ADVANCED - Requires speciality tools. Drilling, cutting, and/or welding
- EXPERT - Professional installation recommended.

DISCLAIMER

Expedition One is not responsible for any damages to vehicle or injury.
 We always recommend professional assistance when installing our vehicle products.

Always follow safety precautions including the use safety gear and devices.

INSTALLATION

1 OEM STEP REMOVAL

If equipped, remove the OEM steps or sliders from the vehicle.

2 TREAD PLATE INSTALLATION

Install the tread plates on the rocker guards using the provided 1/4" hardware.

DRIVERS SIDE SHOWN

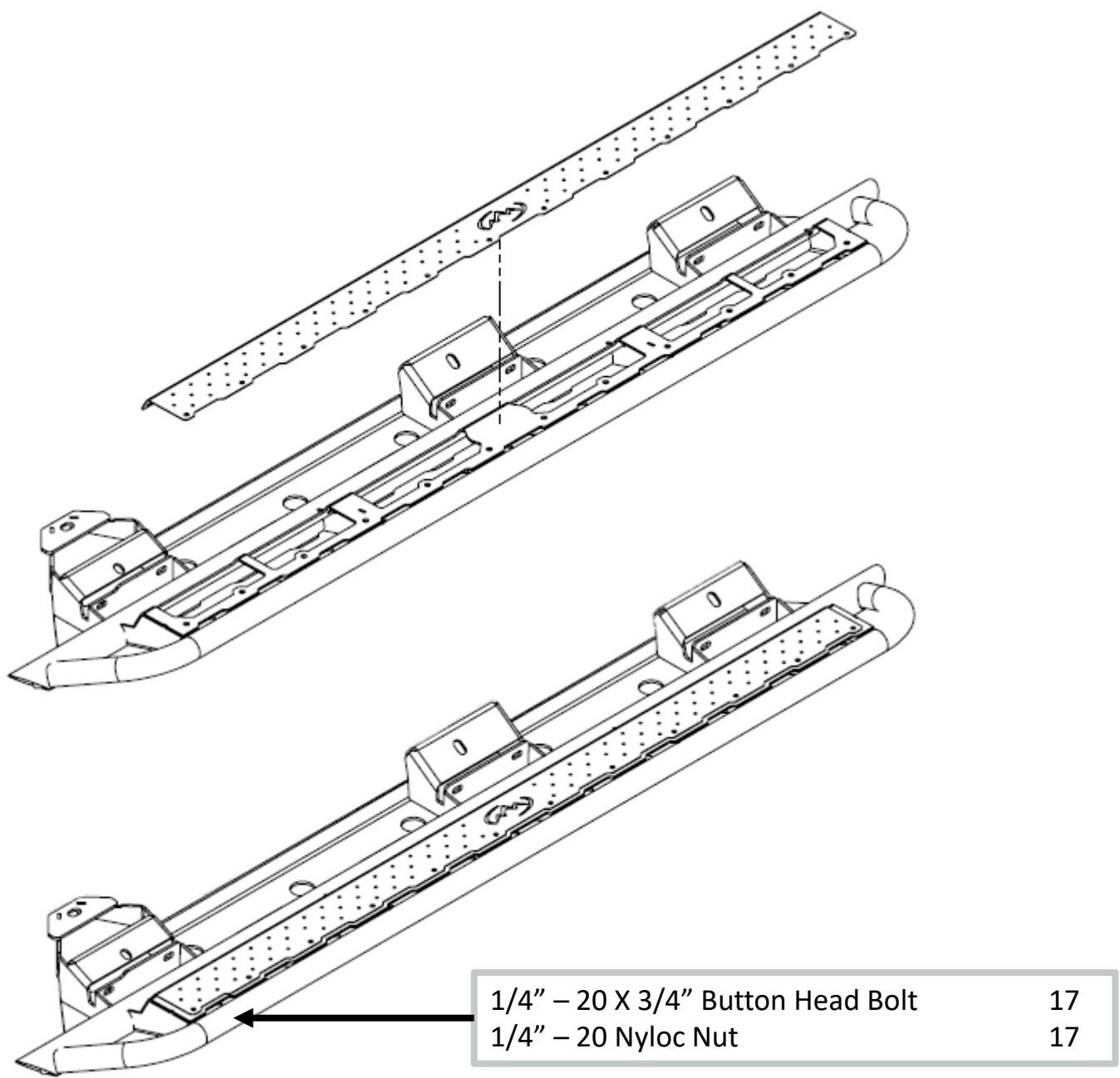

3 WIRE LOOM MOVEMENT

Drivers side may require unclipping the wire loom and its cradle to make room for the rocker guard. Secure out of the way or reattach once installed.



4 ROCKER GUARD MOUNTING

Attach the rocker guard as shown by slotting it into the pinch seam and underside. Mount using the provided hardware. Leave all hardware loose for adjustment, repeat for the other side.

DRIVERS SIDE SHOWN

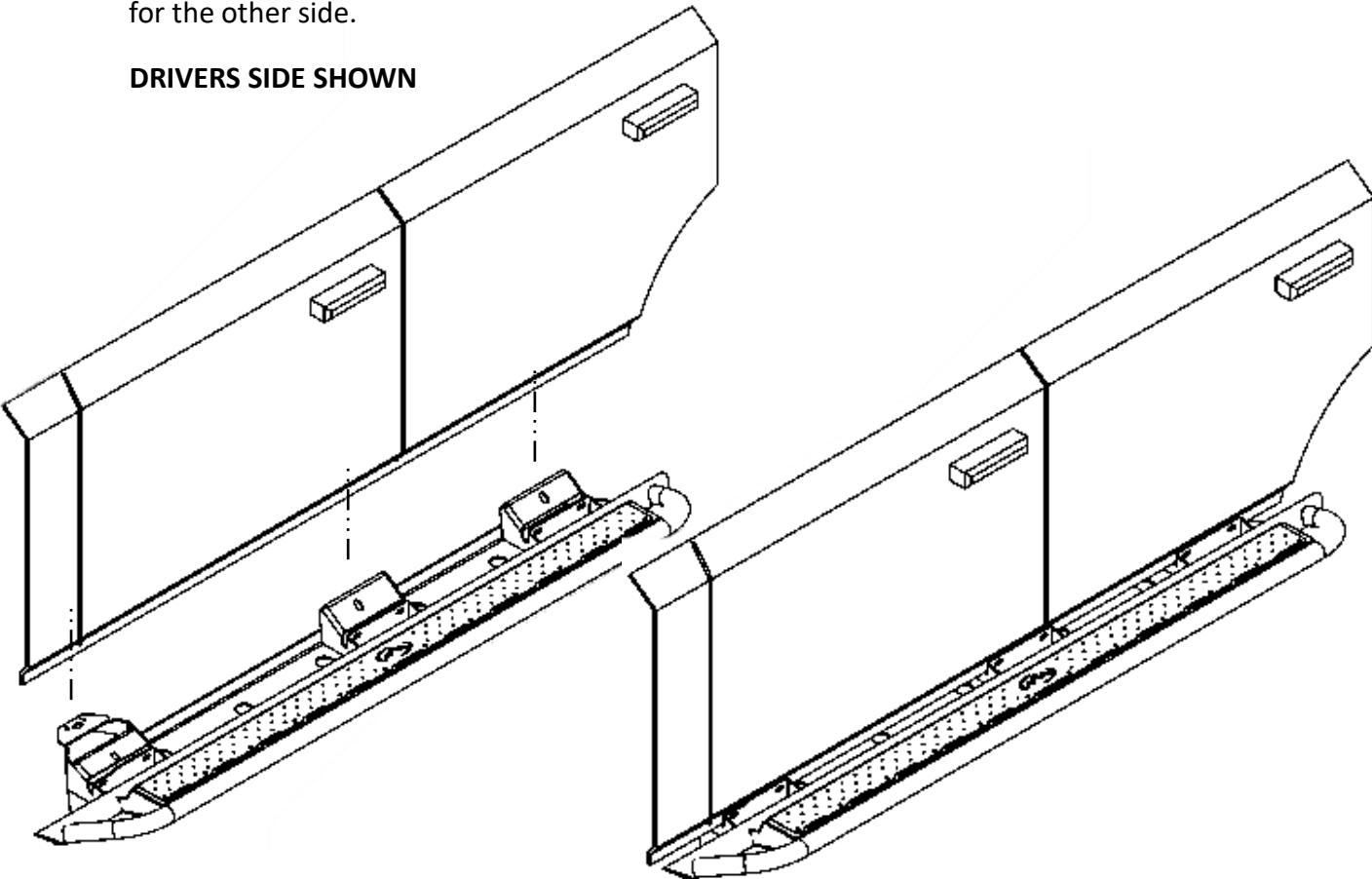

CONTINUED

Mount using the provided M10 Bolts and 3/8" Washers in the circled OEM threaded locations.

DRIVERS SIDE SHOWN

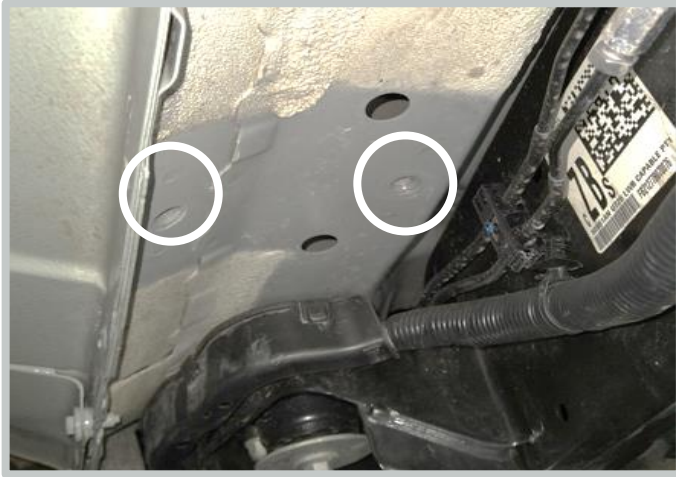

M10 – 1.5 X 40mm Hex Cap Bolt
3/8" USS Washer

4

4

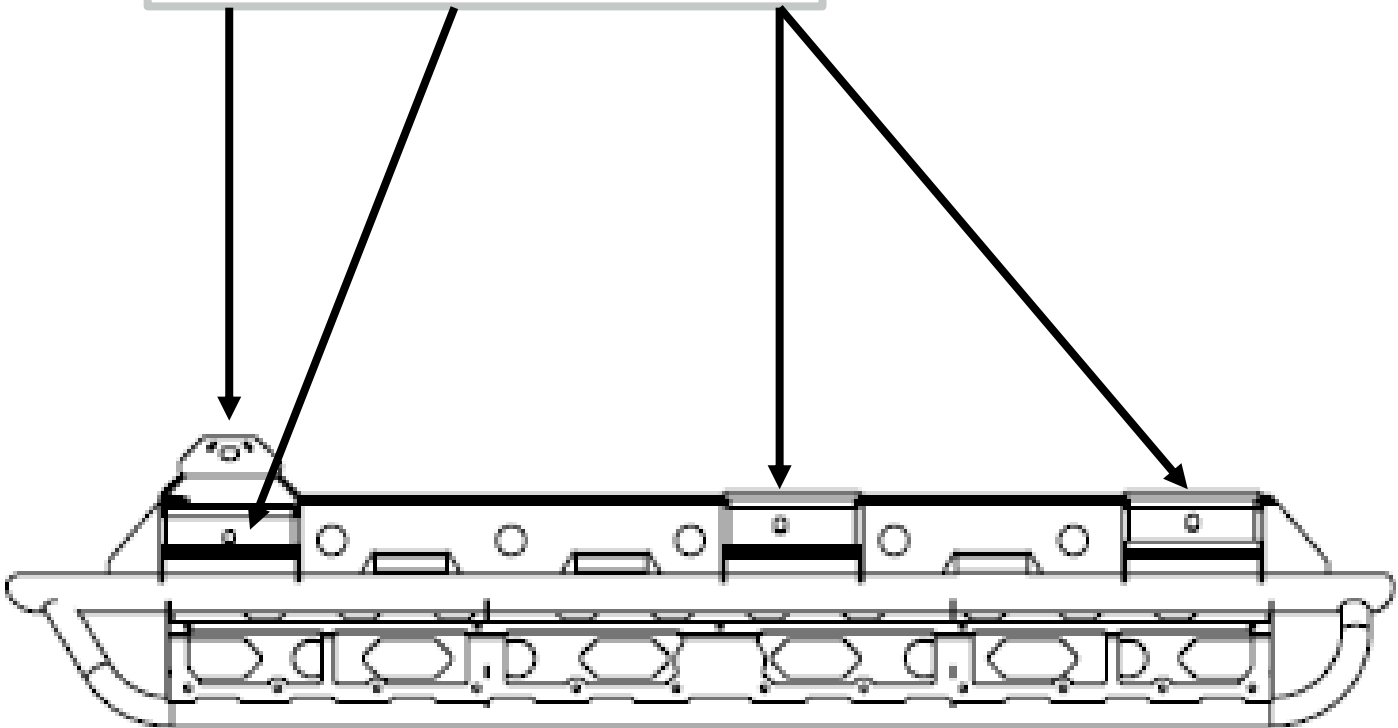

CONTINUED

Mount to the pinch seam using the provided 5/16" Hardware in the circled OEM hole locations.

DRIVERS SIDE SHOWN

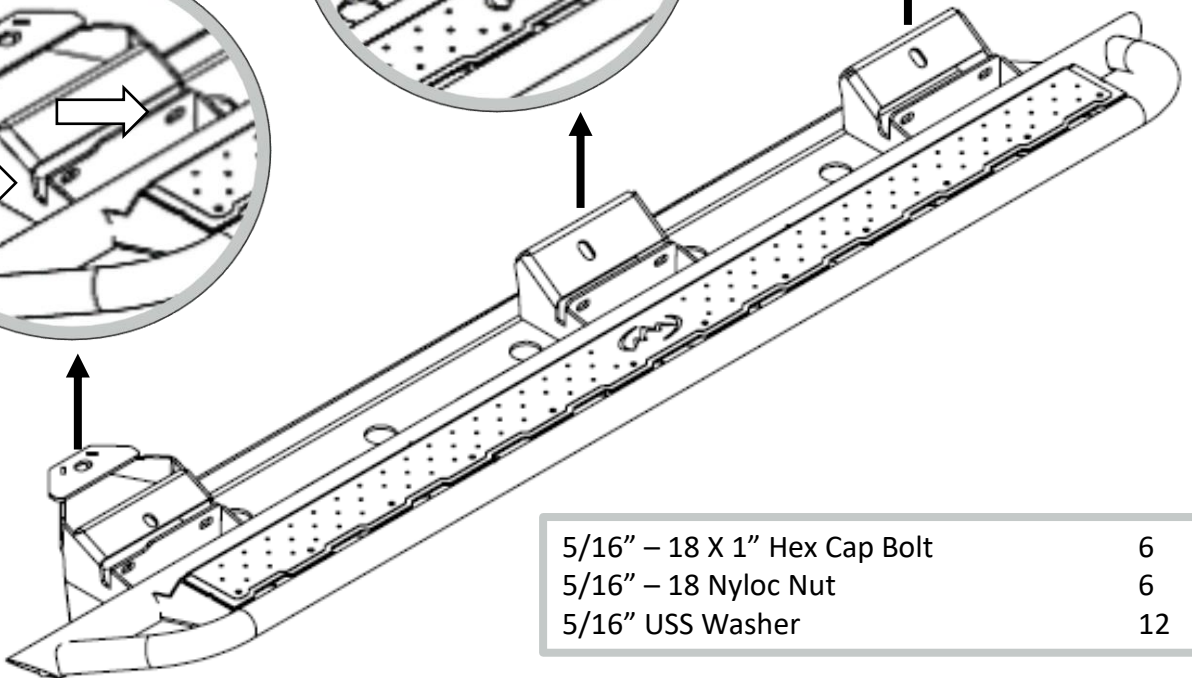
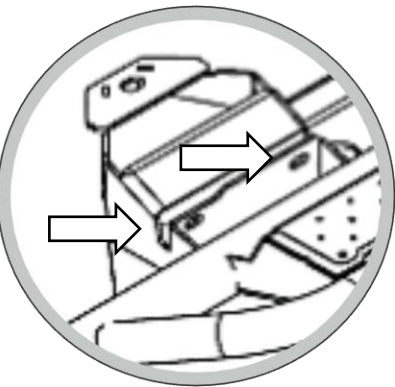
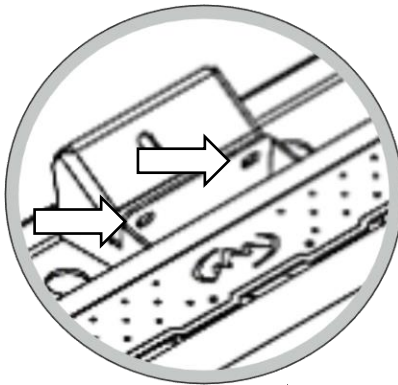
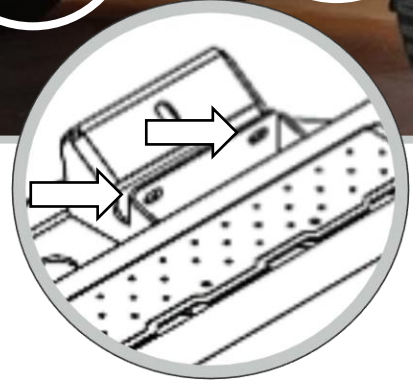
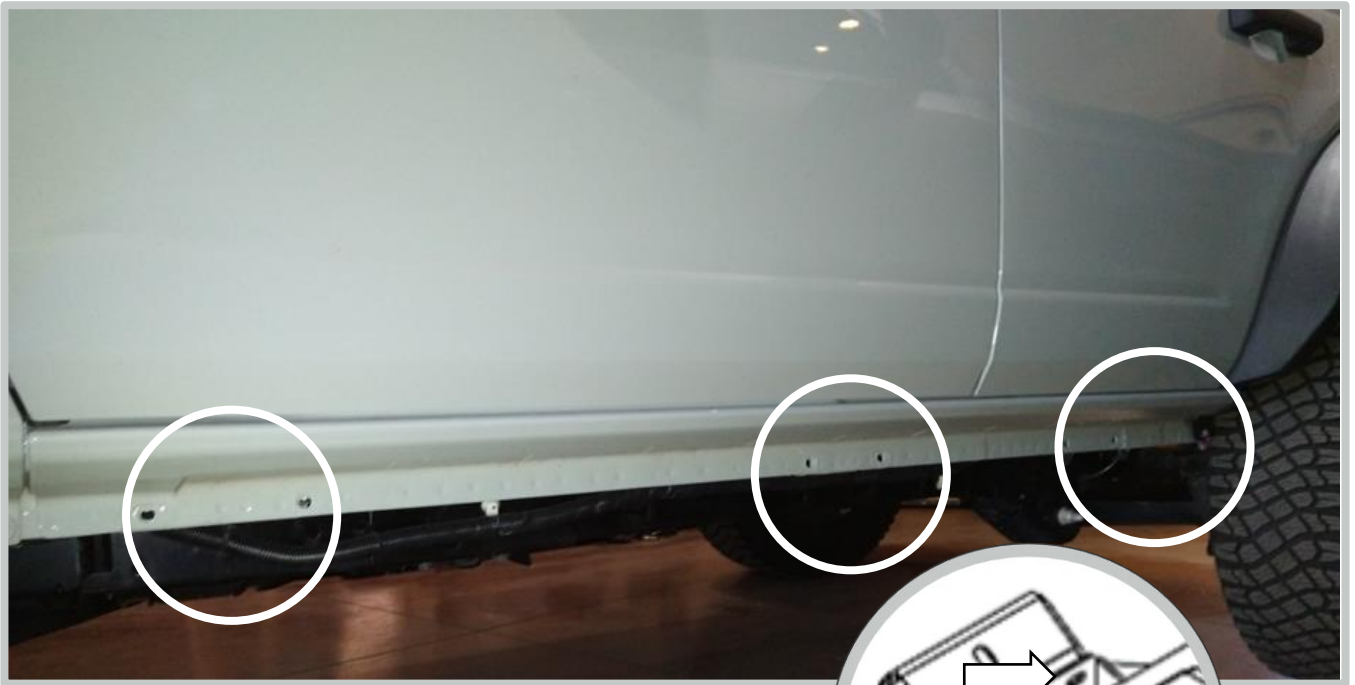

5/16" – 18 X 1" Hex Cap Bolt	6
5/16" – 18 Nyloc Nut	6
5/16" USS Washer	12

CONTINUED

DRIVERS SIDE SHOWN



5 **HARDWARE**

Check that all hardware has been installed. Once complete align and center the rocker guards with the vehicle. Even and equally space all gaps and spaces with the vehicle.

TIGHTEN ALL HARDWARE.

CHECK HARDWARE REGULARLY AND TIGHTEN AS NEEDED, INCLUDING AFTER OFFROAD USE.