

INSTALLATION GUIDE

FJ CRUISER- 4RUNNER WASHER FLUID KIT

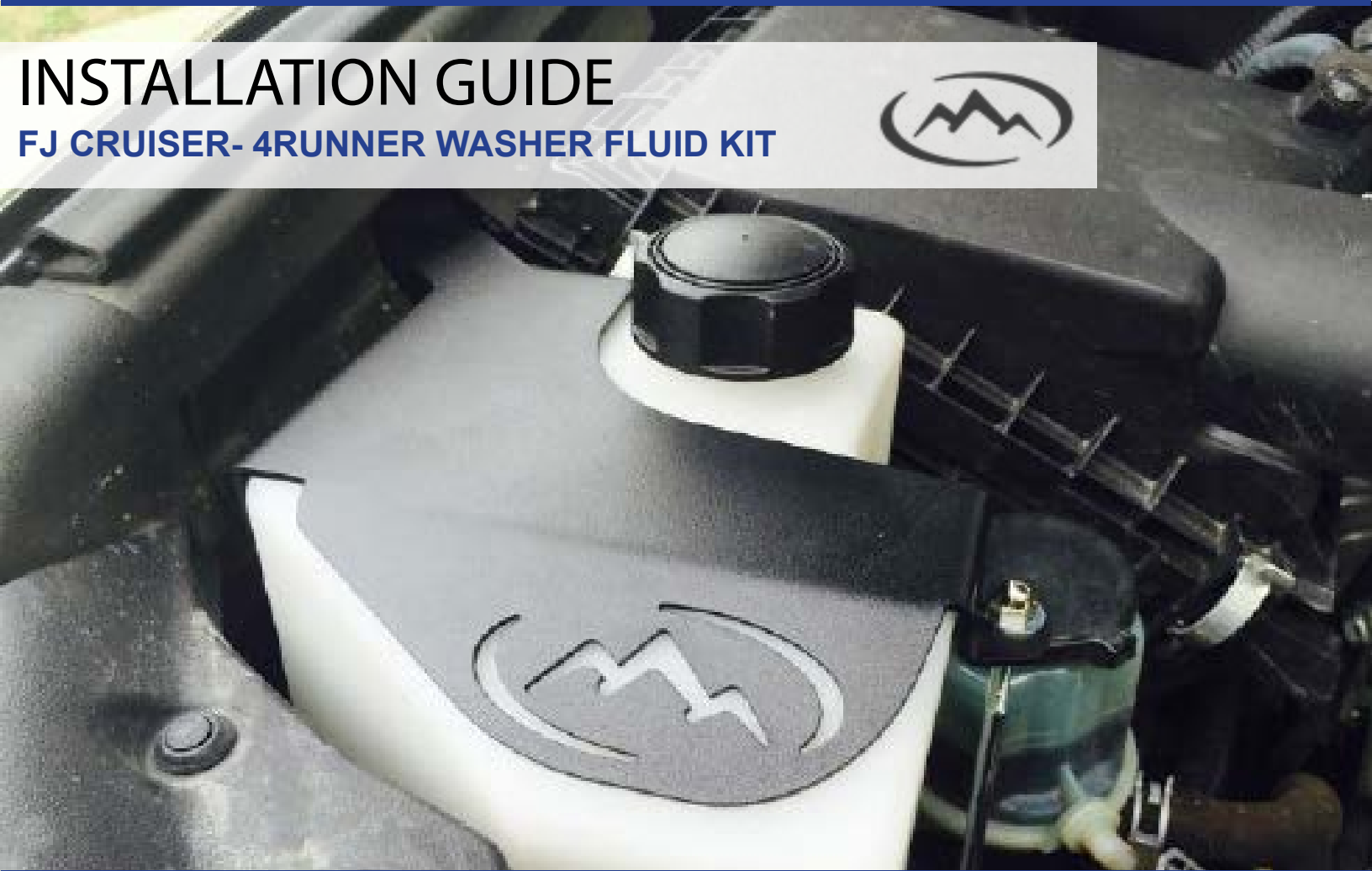

CONTENTS

HARDWARE

ITEM	QTY
A - Washer Fluid Reservoir Bottle	1
B - Top Plate	1
C - Bottom Plate	1
Washer Kit Hardware	
1/4"-20 J Bolt	1
1/4"-20 Clip Nut	1
1/4" SAE Washer	5
5/16"-18 X 3/4" Hex Cap Bolt	3
M6 - 1.0 X 10mm Hex Cap Bolt	1
AIR PUMP KIT (FJ 13+ or 4R ONLY)	
D - Bracket 1	1
E - Bracket 2	1
Air Pump Washer Kit Hardware	
M8- 1.25 X 20mm Hex Cap Bolt	3
M8-1.25 Nyloc Nut	6
M8 Washer	9
Wiring - 14 & 18 GA Wire 24" Length	4
Communications Wire 24" Length	1
Connectors	8
Heater Hose 16" Length	1

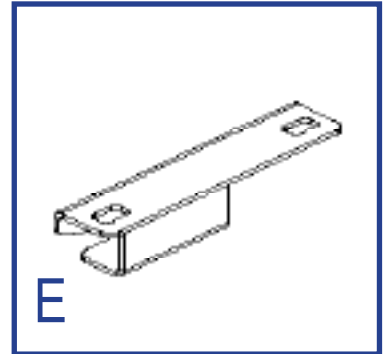
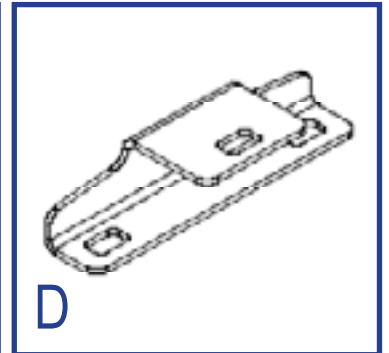
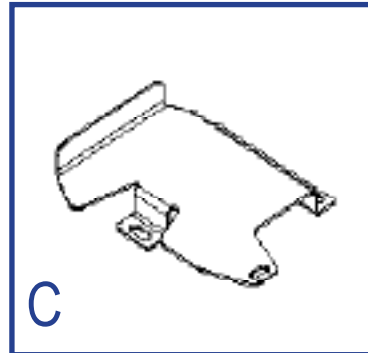
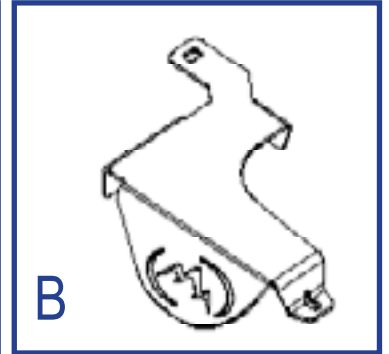
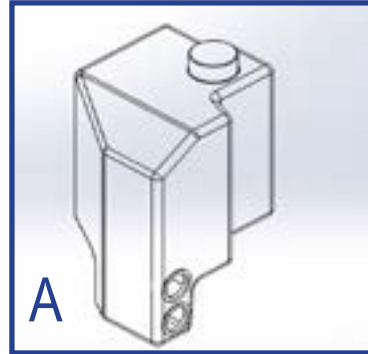

SKILL LEVEL - 2 STARS



- 1 STAR ★☆☆☆☆
- 2 STARS ★★☆☆☆
- 3 STARS ★★★☆☆
- 4 STARS ★★★★☆
- 5 STARS ★★★★★

- EASY - No tools required
- BASIC - Requires standard tools, basic mechanical knowledge and understanding
- MODERATE - Requires standard tools. Some drilling and/or cutting.
- ADVANCED - Requires speciality tools. Drilling, cutting, and/or welding
- EXPERT - Professional installation recommended.

DISCLAIMER

Expedition One is not responsible for any damages to vehicle or injury.
 We always recommend professional assistance when installing our vehicle products.
 Always follow safety precautions including the use of safety gear and devices.
 Check regularly that all bumper hardware tight and secure.
 Maintain and service systems such as bearings or assemblies as recommended.

NOTE - WE REMOVED THE AIRBOX AND UNPLUGGED M.A.F. (Mass Air Flow) FOR PHOTOS ONLY. YOU DO NOT NEED TO DO THAT. IF YOU UNPLUG ANY ELECTRICAL TO THE AIR BOX/AIR FILTER, YOU WILL GET AN ENGINE ERROR CODE AND YOU WILL NEED TO DO A RESET OF THE E.C.M. (Engine Computer)

FJ 2009-2012 INSTALLATION

1 REMOVAL OF OEM RESERVIOR

Empty the OEM Reservoir and remove from the vehicle.

2 INSTALLATION

Attach the base plate as shown using the provided hardware.



3 INSTALLATION

First rinse and clean out the replacement reservoir before installing. Mount the bottle to the base plate and secure using the provided hardware. Be sure to transfer your pumps and gaskets to the new reservoir, and prepare to position them to be reconnected. Use some dish soap as a lubricant when fitting the pumps into the gasket.



FJ 2013 & 4RUNNER w/ AIR PUMP INSTALLATION

1 REMOVAL OF OEM RESERVOIR

Empty the OEM Reservoir and remove from the vehicle.

2 AIR PUMP RELOCATION

Unbolt and remove the hosing on the pump kit (arrow) from its factory location as shown below. You will also need to unclip the electrical end and reroute that around the air filter box to its new location once the air pump is relocated.

FJ Cruiser - electrical wiring will need to be spliced and extended to reach the new location of the air pump.

Once its removed, you will need to attach the two small air pump brackets provided on the bottom of the air pump as shown below with the provided hardware.



AIR PUMP RELOCATION CONT.

Once your brackets are secured, place it at the top corner of your engine bay on the passenger side as shown below. Using the included bolts, tighten down the three bracket bolt locations with a socket and extension.

You will also need to reroute the hosing underneath the air filter box as shown (arrow), And using the provided hose extension to reattach the hose line to your air pump.



3 INSTALLATION

Attach the base plate as shown using the provided hardware.



4 INSTALLATION

First rinse and clean out the replacement reservoir before installing. Mount the bottle to the base plate and secure using the provided hardware. Be sure to transfer your pumps and gaskets to the new reservoir, and prepare to position them to be reconnected. Use some dish soap as a lubricant when fitting the pumps into the gasket. Reattach all connections once completed.

