

INSTALLATION GUIDE

GEN 3 TIRE CARRIER NATO CAN MOUNT

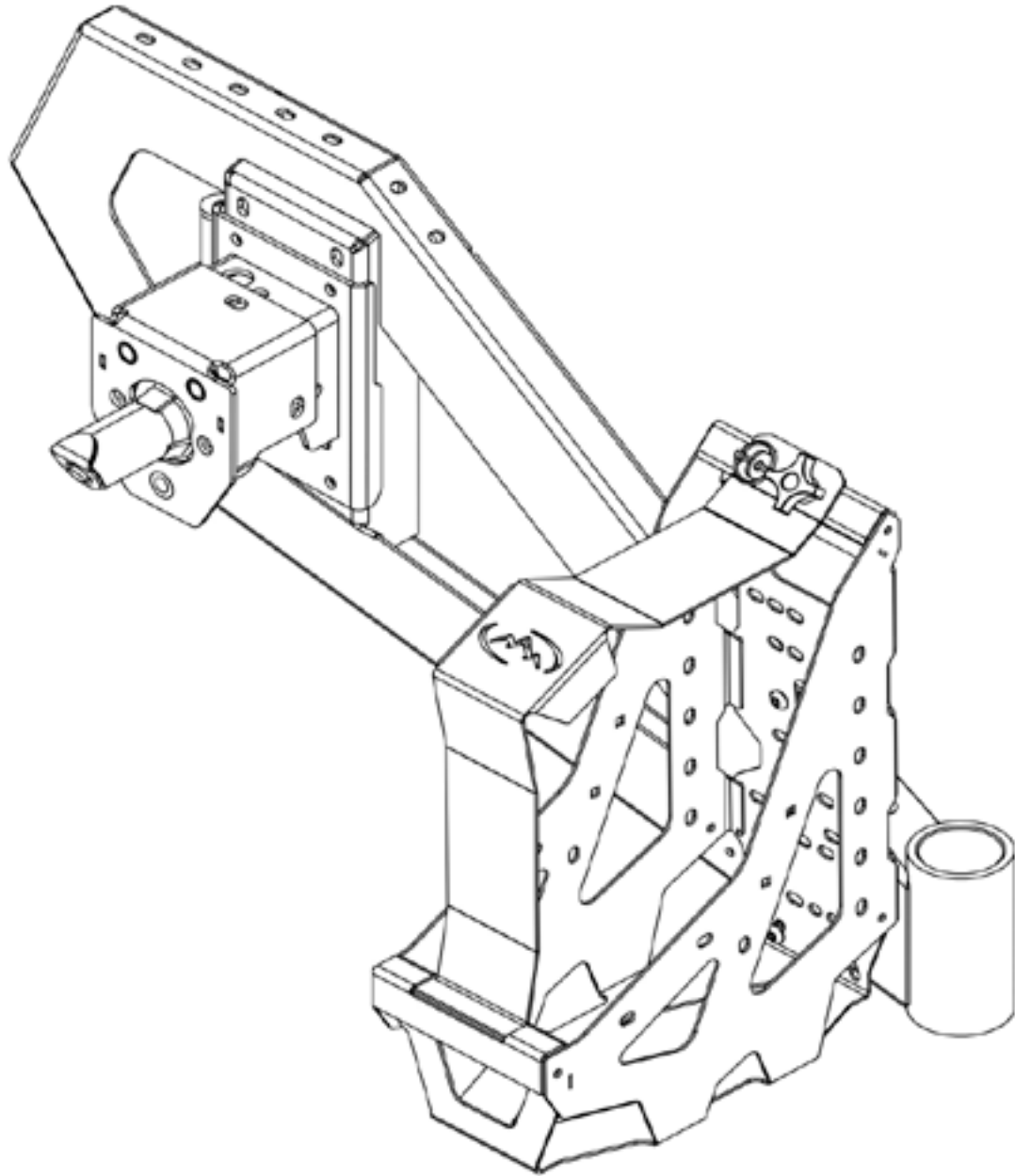

CONTENTS

FOR USE ON GEN 3 TIRE CARRIER SWING ARMS - FJ CRUISER AND JK/JL WRANGLER

HARDWARE

ITEM	QTY
Nato Can	1
Nato Can Strap	1
Nato Can Knob	1
3/8"-16 Clip Nut	1
Linch Pin	1
Top Plate	1
Bottom Plate	1
FJ/JK/JL NATO Mounting Hardware	1
3/8"-16 X 1" Button Head BoltS	8
3/8"-16 X 1" Nyloc Nuts	8



SKILL LEVEL - 2 STARS



1 STAR ★☆☆☆☆

EASY - No tools required

2 STARS ★★☆☆☆

BASIC - Requires standard tools, basic mechanical knowledge and understanding

3 STARS ★★★☆☆

MODERATE - Requires standard tools. Some drilling and/or cutting.

4 STARS ★★★★☆

ADVANCED - Requires speciality tools. Drilling, cutting, and/or welding

5 STARS ★★★★★

EXPERT - Professional installation recommended.

DISCLAIMER

Expedition One is not responsible for any damages to vehicle or injury.
We always recommend professional assistance when installing our vehicle products.

Always follow safety precautions including the use safety gear and devices.

GEN 3 TIRE CARRIER NATO MOUNT

1 NATO CAN

Assemble the Nato Can as shown.

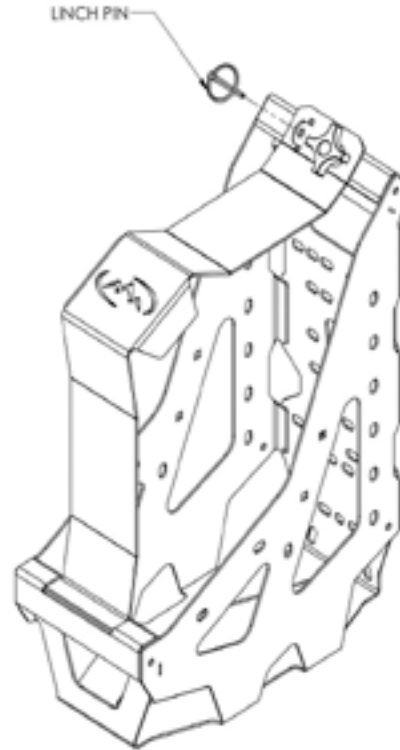

2 MOUNTING PLATES

Attach the top and bottom plates as shown.

JK/JL SWING ARM SHOWN - FJ IS MIRRORED

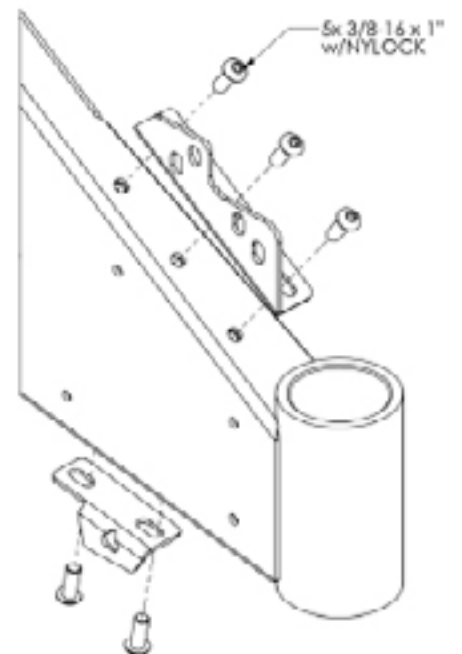

3 NATO CAN MOUNTING

Attach the Nato Can as shown using the provided hardware.

JK/JL SWING ARM SHOWN - FJ IS MIRRORED

