

INSTALLATION GUIDE

FORD RANGER SKID PLATE



CONTENTS

HARDWARE

ITEM	QTY
<u>A</u> Front Skid Plate	1
<u>B</u> Mid Skid Plate	1
<u>C</u> Skid Plate Mount Brackets	2
Ranger Skid Plate Hardware Kit	1
3/8" - 16 X 1 1/2" Hex Cap Bolt	4
3/8" - 16 Nyloc Nut	4
3/8" - SAE Washer	8

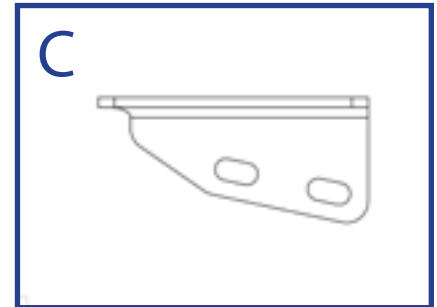
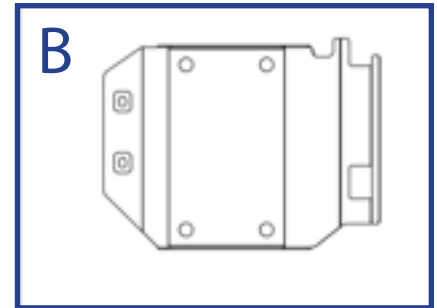
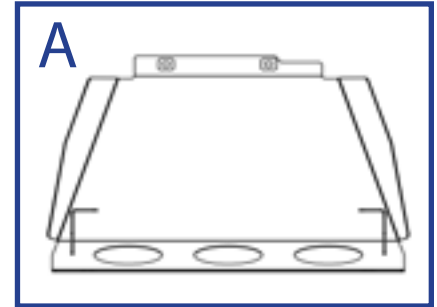

SKILL LEVEL - 3 STARS



- 1 STAR ★☆☆☆☆
- 2 STARS ★★☆☆☆
- 3 STARS ★★★☆☆
- 4 STARS ★★★★☆
- 5 STARS ★★★★★

- EASY - No tools required
- BASIC - Requires standard tools, basic mechanical knowledge and understanding
- MODERATE - Requires standard tools. Some drilling and/or cutting.
- ADVANCED - Requires speciality tools. Drilling, cutting, and/or welding
- EXPERT - Professional installation recommended.

DISCLAIMER

Expedition One is not responsible for any damages to vehicle or injury.
We always recommend professional assistance when installing our vehicle products.

Always follow safety precautions including the use of safety gear and devices.

FRONT BUMPER REMOVAL

1 REMOVE LOWER FASCIA

Disconnect the wiring harness for the front bumper. Remove sensors from the bezels and disconnect front fog lights if applicable. Start by removing the lower fascia by undoing the clips and prying it away from the bumper.



2 BUMPER REMOVAL

Remove the hardware connecting the bumper to the frame and pull the bumper off the vehicle.



3 SKID PLATE AND TOW HOOK REMOVAL

Remove both the stock skid plate and tow hooks from the front bumper.



SKID PLATE INSTALLATION

4 SKID PLATE INSTALL

Mount the mid skid plate first using OEM hardware to the cross member as shown below. Next attach the skid plate brackets to the bottom of the frame with OEM hardware before attaching the front skid with the provided 3/8" hardware. Finish mount both skid plates with remaining hardware and tighten.

