

# INSTALLATION GUIDE

## GEN 2 TIRE CARRIER HI-LIFT/PULL PAL MOUNT

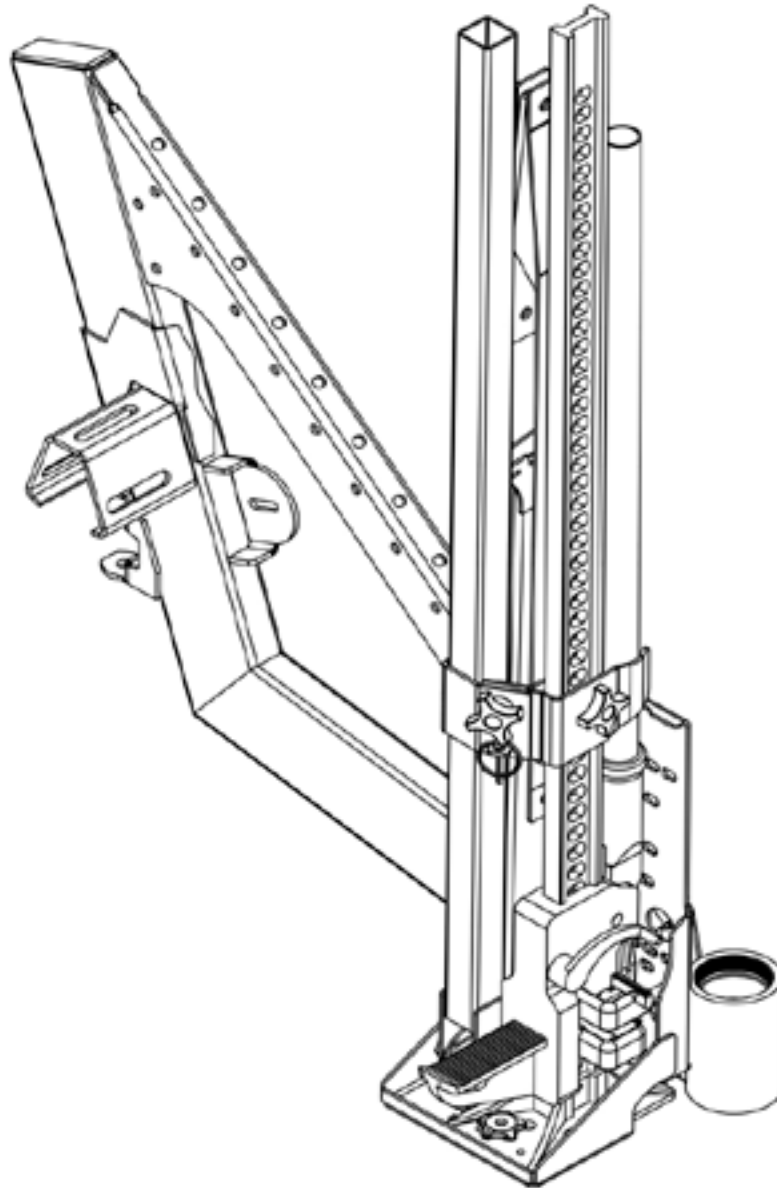

# CONTENTS

FOR USE ON GEN 2 TIRE CARRIER SWING ARMS - FJ CRUISER AND JK WRANGLER

## HARDWARE

ITEM	QTY
Hi-Lift	1
Hi-Lift Pull Pal Plates	3
Hi-Lift Knob	2
Hi-Lift Knob No Thread	1
5/16" - 18 X 3/4" Button Head Bolts	2
5/16" - 18 X 1" Carriage Bolt	1
5/16" - 18 Nyloc Nuts	2
3/8" - 16 Clip Nut	2
Linch Pin	1
Top Plate	1
FJ/JK Bottom Plate	1
FJ/JK NATO Mounting Hardware	1
3/8"-16 X 1 1/4" Button Head Bolt	1
3/8"-16 X 2 1/2" Button Head Bolts	2
3/8" Washer	3
3/8"-16 X 1" Nyloc Nuts	3



## SKILL LEVEL - 2 STARS



- 1 STAR ★☆☆☆☆
- 2 STARS ★★☆☆☆
- 3 STARS ★★★☆☆
- 4 STARS ★★★★☆
- 5 STARS ★★★★★

- EASY - No tools required
- BASIC - Requires standard tools, basic mechanical knowledge and understanding
- MODERATE - Requires standard tools. Some drilling and/or cutting.
- ADVANCED - Requires speciality tools. Drilling, cutting, and/or welding
- EXPERT - Professional installation recommended.

## DISCLAIMER

Expedition One is not responsible for any damages to vehicle or injury. We always recommend professional assistance when installing our vehicle products.

Always follow safety precautions including the use safety gear and devices.

# GEN 2 TIRE CARRIER HI-LIFT PULL PAL MOUNT

## 1 HI-LIFT PULL PAL ASSEMBLY

Assemble the Hi-Lift Pull Pal as shown.

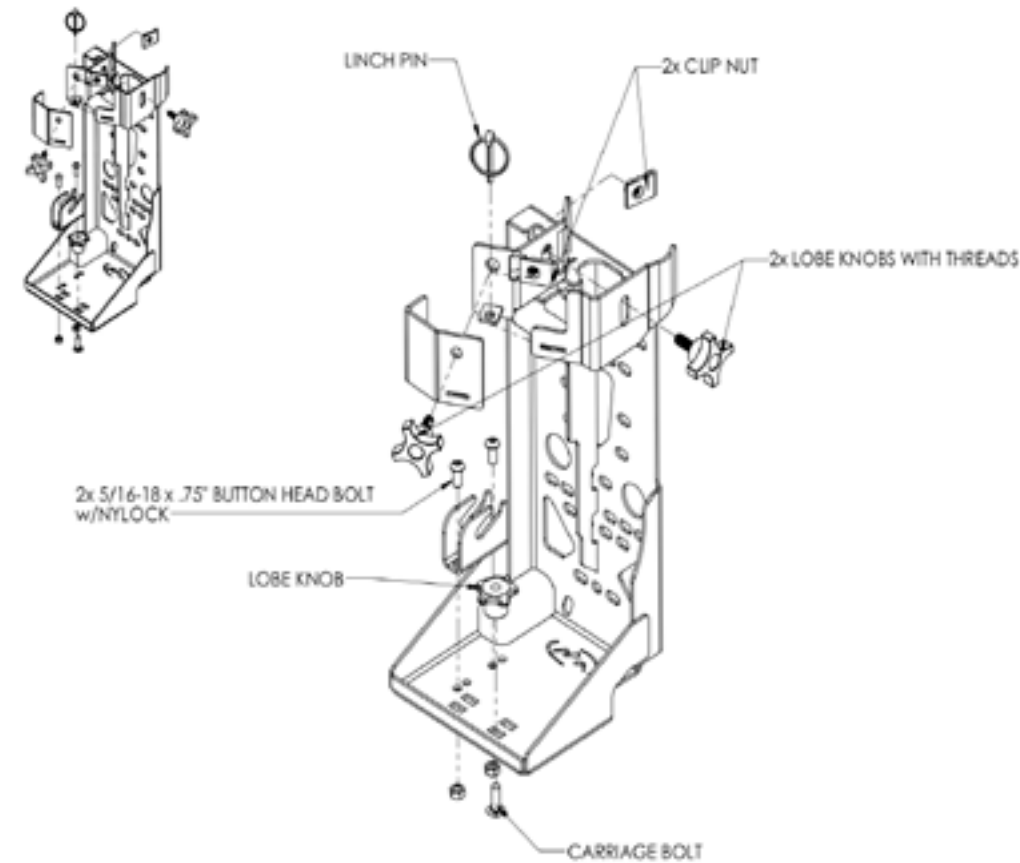

## 2 MOUNTING PLATES

Place the top and bottom plates as shown.

JK SWING ARM SHOWN - FJ IS MIRRORED

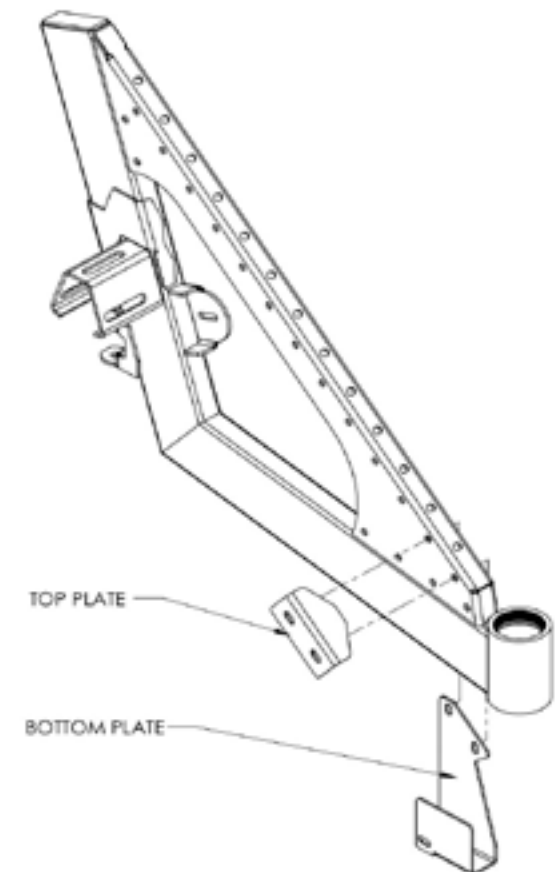

---

### 3 HI-LIFT PULL PAL MOUNTING

Attach the Hi-Lift Pull Pal as shown using the provided hardware.

JK SWING ARM SHOWN - FJ IS MIRRORED

