

INSTALLATION GUIDE

GEN 2 TIRE CARRIER HI-LIFT MOUNT

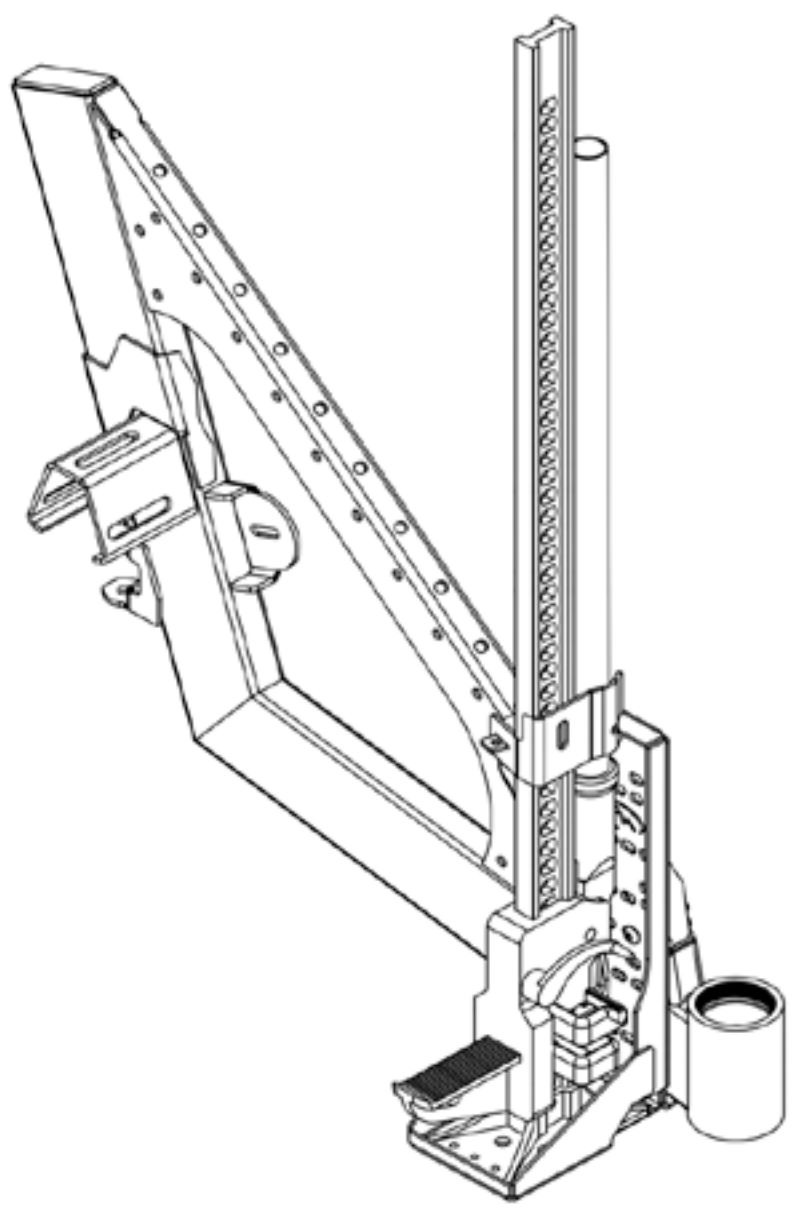

CONTENTS

FOR USE ON GEN 2 TIRE CARRIER SWING ARMS - FJ CRUISER AND JK WRANGLER

HARDWARE

ITEM	QTY
Hi-Lift	1
Hi-Lift Plate	1
Hi-Lift Knob	1
Hi-Lift Knob No Thread	1
5/16" - 18 X 1" Carriage Bolt	1
3/8" - 16 Clip Nut	1
Linch Pin	1
Top Plate	1
FJ/JK Bottom Plate	1
FJ/JK NATO Mounting Hardware	1
3/8"-16 X 1 1/4" Button Head Bolt	1
3/8"-16 X 2 1/2" Button Head Bolts	2
3/8" Washer	3
3/8"-16 X 1" Nyloc Nuts	3



SKILL LEVEL - 2 STARS



- 1 STAR ★☆☆☆☆
- 2 STARS ★★☆☆☆
- 3 STARS ★★★☆☆
- 4 STARS ★★★★☆
- 5 STARS ★★★★★

- EASY - No tools required
- BASIC - Requires standard tools, basic mechanical knowledge and understanding
- MODERATE - Requires standard tools. Some drilling and/or cutting.
- ADVANCED - Requires speciality tools. Drilling, cutting, and/or welding
- EXPERT - Professional installation recommended.

DISCLAIMER

Expedition One is not responsible for any damages to vehicle or injury. We always recommend professional assistance when installing our vehicle products.

Always follow safety precautions including the use safety gear and devices.

GEN 2 TIRE CARRIER HI-LIFT MOUNT

1 HI-LIFT ASSEMBLY

Assemble the Hi-Lift as shown.

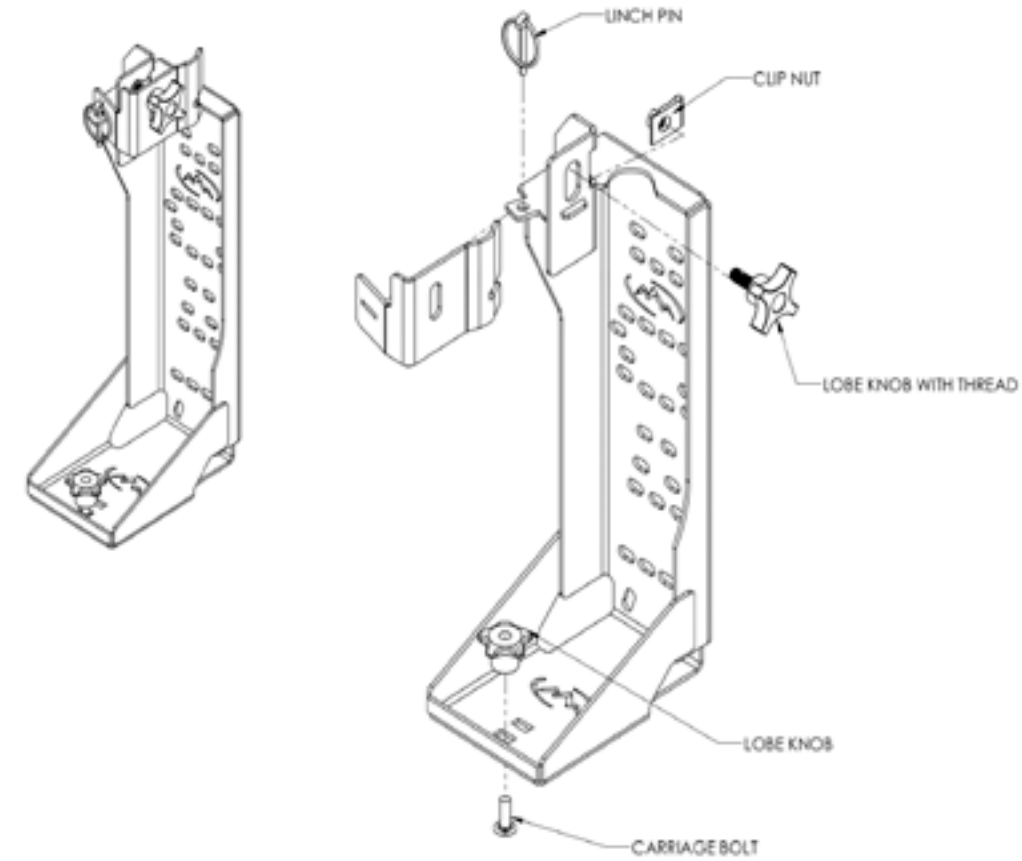

2 MOUNTING PLATES

Place the top and bottom plates as shown.

JK SWING ARM SHOWN - FJ IS MIRRORED

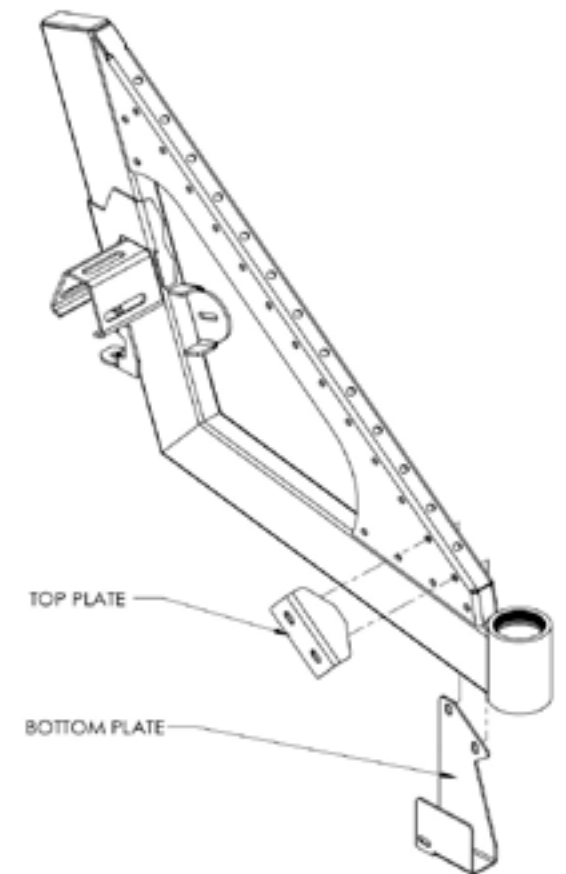

3 HI-LIFT MOUNTING

Attach the Hi-Lift as shown using the provided hardware.

JK SWING ARM SHOWN - FJ IS MIRRORED

