



2021+ FORD BRONCO BASE & DSTC REAR BUMPER



PLEASE READ ENTIRE GUIDE BEFORE INSTALLATION

Recommended that you read this entire install guide before installation. Check that all hardware is present before starting or scheduling an install. This guide is supplemental to mechanical knowledge and ability. Anyone not familiar with automotive installation should seek professional installation.

IMPORTANT INFO/FAQ

INSTALLATION HELP

Please review terms and conditions for details

Recommended purchaser review Welcome Guide at time of purchase for details

Care & Maintenance and Install Guides available at www.exp-one.com/resources

We do our best to offer timely assistance with your installation questions however as most of our team members are primarily engaged in the manufacturing process and packaging processes, we do not currently offer a tech for on-demand calls and inquiries. For the more technical installs or installs that are time-sensitive in nature, we would recommend our customers seek out the services of professional shops with experience specific to aftermarket bumpers.. We are happy to make recommendations to you on shops familiar with our products in your area. We do our best to respond to installation questions within 24-48 hours of contact as much as possible. Long-distance problem assessment can be difficult, so photos and videos are often required for us to best assist you. We highly recommend your initial contact regarding installation questions include both close-up and full photos, detailed descriptions using our part descriptions as much as possible, and video. This enables us to better assist without having the ability to see the install difficulties directly and assist you as quickly as possible.

NOTE

Expedition One does not guarantee fitment with other aftermarket products, or reinstallation of take off OEM parts.

Expedition One is NOT RESPONSIBLE for damage to paint or powder coating, items assembled in error during installation or costs associated with install, and injury.

OEM manufacture model refreshes/updates, factory build location and suppliers may cause variations in fitment or installation and can not be verified, vehicle to vehicle .

EXPEDITION ONE
113 N. 700 W. BUILDING 5C BAY 1
OGDEN, UT 84404
INFO@EXPEDITIONONE.BIZ
801-627-2921 MON-FRI 0900-1700 MST

INSTALL LEVEL



- | | | |
|---------|-------|--|
| 1 STAR | ★ | EASY - No tools required |
| 2 STARS | ★★ | BASIC - Requires standard tools, basic mechanical knowledge and understanding |
| 3 STARS | ★★★ | MODERATE - Requires standard tools. Some drilling and/or cutting. |
| 4 STARS | ★★★★ | ADVANCED - Requires speciality tools. Drilling, cutting, and grinding required |
| 5 STARS | ★★★★★ | EXPERT - Professional installation recommended. |

We always recommend professional assistance when installing our vehicle products. Always follow safety precautions including the use of safety gear and devices.

IMPORTANT INFO/FAQ

LIGHT PORTS + LIGHT BARS

To give you a wide range of options from various brands and designs, the light ports were designed to be as universal as possible. Not all mounts or designs will fit exactly and may require the use of shims, spacers, removal of housings or covers, different light manufacture mounts or hardware to mount. Reuse of OEM light is limited to select bumpers and will come with provided hardware to reinstall. Specific mounts or options if available will be listed at time of purchase and provided with hardware. Bolt-on light ports or mounts will mount as per the instructions. It is recommended that lights be purchased with the bumper in hand to gain the best fitment. We DO NOT manufacture the lights, provided wiring, or instructions on how to connect to the OEM harness. Seek professional installation on hybrid or electric vehicles

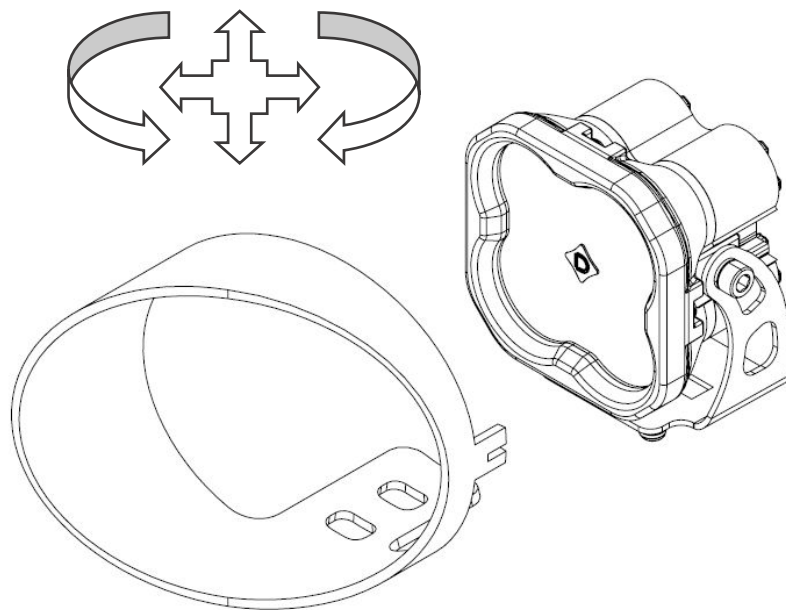

EXAMPLE SHOWN - LIGHT PORTS WILL VARY

AFTERMARKET or OEM PRODUCTS

We DO NOT guarantee fitment or installation of any aftermarket, third party or OEM parts, accessories, or hardware. This includes items such as lighting, winches, skids, lifts, suspension, and accessory mounts. Access to all brands, manufactures and country of origin specific parts is limited or impossible during the product development stage and subsequent new or modified revisions of said products including OEM design changes or refreshes. It is recommended you have the product in hand and installed before modifying with other aftermarket parts. Consult other sources to gain any first hand knowledge of other products others have installed.

EXAMPLES

The illustrations, diagrams, and examples shown in this guide are provided for reference purposes only. Actual installations may vary depending on model, configuration, or product updates. Drawings, visuals, and component layouts may differ from what is shown, but the installation principles and procedures remain the same.

USE IN CONJUNCTION WITH DSTC ARM SYSTEMS GUIDE

Swing arm specific items feature a separate guide related to the installation of arms and common features.

Review these guides for any pre planning or items that will need to be installed or in conjunction with the bumper install. Items listed below that may have limited access once installed on the vehicle.

- Tread Plate
- Pin Plates
- Kickplate Assemblies

IMPORTANT INFO/FAQ

HARDWARE

Please review for details and installation. Figures or data may vary. Leave all accessible hardware loose for installation and tighten all hardware after everything is installed on the vehicle. Check and tighten all hardware after the first 100 miles and/or after off roading.

Some hardware locations do not require being tightened to spec due to there design, location or material attachment (including rubber, plastic, and aluminum). Over tightening may break or damage parts. Torque spec may vary, amounts listed are generic.

HARDWARE		TORQUE SPEC	
SIZE	SOCKET	GR5 / 8.8	GR8 / 10.9
#8	1/4"	X	
#10	5/16"		
1/4"	7/16"	6-8	9-10
5/16"	1/2"	13-14	18-20
3/8"	9/16"	23-26	33-37
7/16"	5/8"	37-41	52-58
1/2"	3/4"	57-64	80-90
9/16"	13/16"	82-91	115-129
5/8"	15/16"	112-118	159-180
3/4"	1-1/8"	200-223	282-315
1"	36MM	X	
M6	10MM	9-10	13-15
M8	13MM	22-24	32-35
M10	15MM	44-49	64-72
M12	18MM	76-83	112-123
M14	21MM	102-112	165



GRADE 5

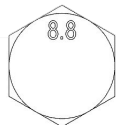



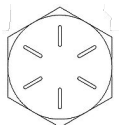



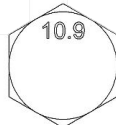







CLASS 8.8



GRADE 8



CLASS 10.9

TYPES OF HARDWARE		
		
HEX CAP BOLT	WASHER	NYLOC NUT
		
BUTTON HEAD BOLT	FENDER WASHER	HEX NUT
		
CARRIAGE BOLT	INTERNAL TOOTH	JAM NUT
		
SOCKET CAP BOLT	CLIP NUT	ACORN NUT
		
FLAT HEAD SCREW	RIVET NUT	COUPLING

NOTE

Extra hardware may be left over due to model or option specific items that may not be required for the install. OEM hardware may vary in style or socket size from shown.

TIGHTEN ALL HARDWARE AFTER EVERYTHING IS INSTALLED ON THE VEHICLE. CHECK AND TIGHTEN ALL HARDWARE AFTER THE FIRST 100 MILES AND AFTER OFF ROADING. CHECK REGULARLY

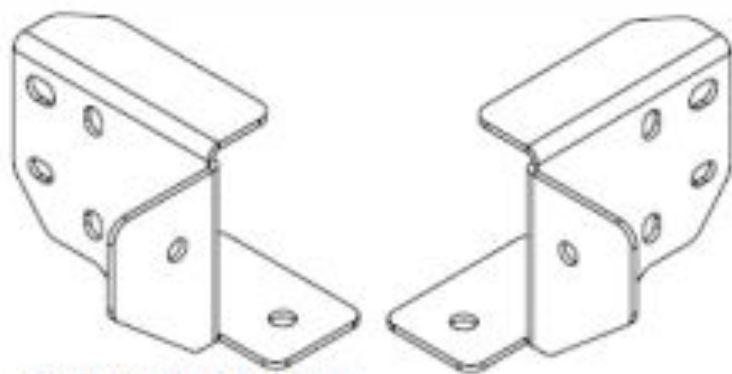

MOUNTNG BRACKETS

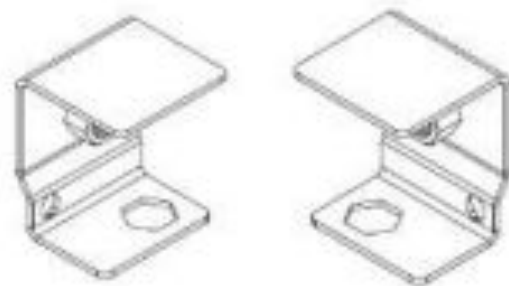

NUT RETAINER BRACKETS

REAR BUMPER HARDWARE

1/2" – 13 X 1 1/4" HEX CAP BOLT	10
1/2" – 13 NYLOC NUT	10
1/2" USS WASHER	20
5/8" – 11 X 1 1/2" HEX CAP BOLT	2
5/8" USS WASHER	2

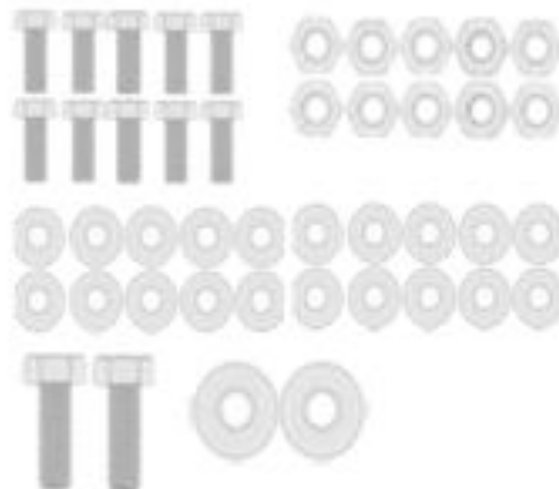

TREADPLATE & HARDWARE

1/4"-20 X 3/4" BUTTON HEAD	10
1/4"- 20 NYLOC NUT	10



LICENSE PLATE MOUNT

LUG BRACKET

SENSOR BEZELS

LICENSE PLATE MOUNT HARDWARE

LUG – 12 X 1.5	3
BRONZE BUSHING	4
8 – 32 X 1/2" BUTTON HEAD	2
8 – 32 NYLOC NUT	2
M12 – 1.5 X 45MM HEX CAP	2
M12 – 1.5 X 50MM HEX CAP	2

LICENSE PLATE LIGHT	1
1/4"-20 X 3/4" HEX CAP BOLT	2
1/4"- 20 NYLOC NUT	2
1/4" USS WASHER	2
5/16"-18X3/4" CARRIAGE	1
5/16" – 18 NYLOC NUT	1
5/16" USS WASHER	2

1 REMOVE OEM BUMPER

- Disconnect the wiring loom on the drivers side.
- Remove the frame bolts (Circled) to remove the bumper.
- Check for any remaining hardware or connections before removing the bumper.
- Keep OEM hardware for reinstallation on the new bumper



2 REMOVE THE BUMPER

Remove the bumper from the vehicle.

3 OEM BUMPER HARDWARE REMOVAL

Remove the wiring loom and sensors by removing any clips or mounts located on the inside of the bumper

4 PARKING SENSOR INSTALLATION (IF APPLICABLE)

Place the OEM wiring harness into the new bumper, threading the wiring through so that connectors match their respective positions. Make sure the wiring harness connector is located on the correct side of the vehicle. Reattach all 4 parking sensors to the provided sensor bezels. Avoid placing the wiring harness near mounting holes and visible cutouts. Mount any aftermarket lights at this time.

NOTE - The license plate will be relocated to the tire or another place of your choosing. The wiring for this can be extended at this point. We do not provide any hardware or parts for the wiring.

5 TREAD PLATE INSTALLATION

Mount the tread plate as shown using the provided 1/4"

BASE BUMPER SHOWN

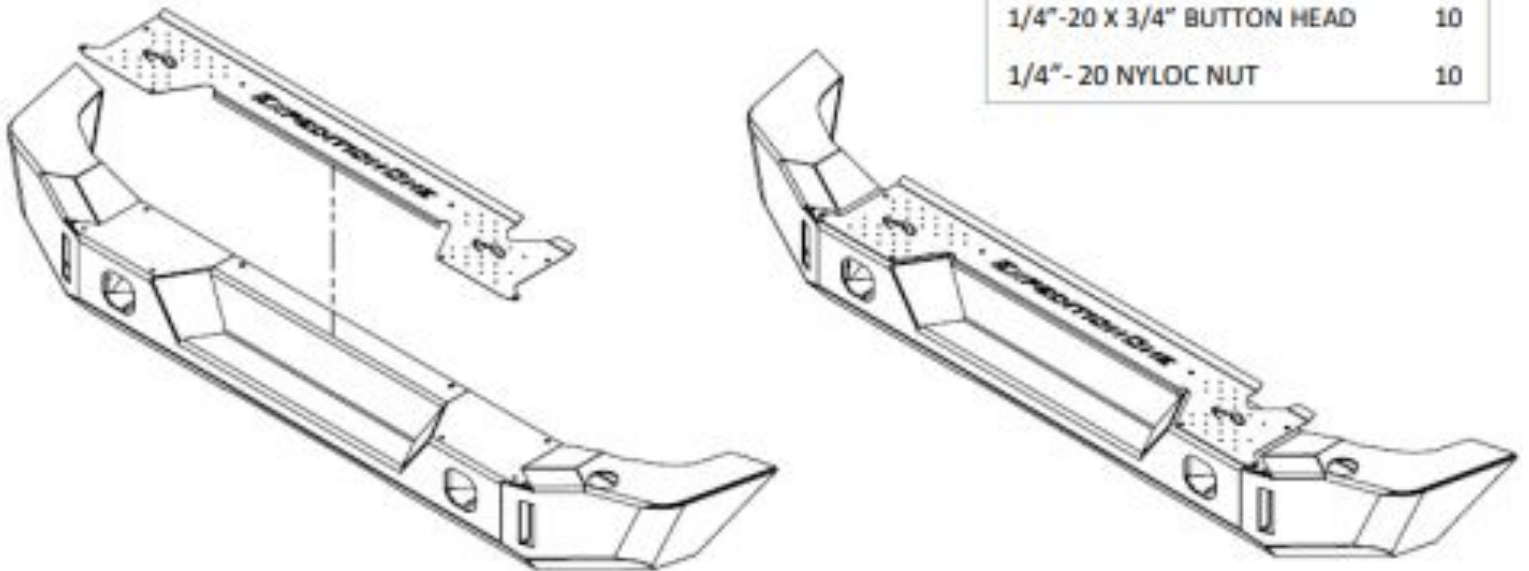

DSTC BUMPERS - SEE ARM SYSTEMS GUIDE

Install Drop Pin Plates, and Kick Plates from DSTC Arm Systems guide.

6 NUT RETAINER BRACKET LOCATION

Place the provided nut retainer brackets inside the frame as shown.



7 MOUNTING BRACKET

Attach the mounting brackets to the vehicle as shown using the provided 1/2" hardware and bottom OEM hardware. Leave all hardware loose for adjustment, this is just to hold the bracket in place for mounting the bumper.



1/2" - 13 X 1 1/4" HEX CAP BOLT	2
1/2" - 13 NYLOC NUT	2
1/2" USS WASHER	4

OEM HARDWARE	4
--------------	---

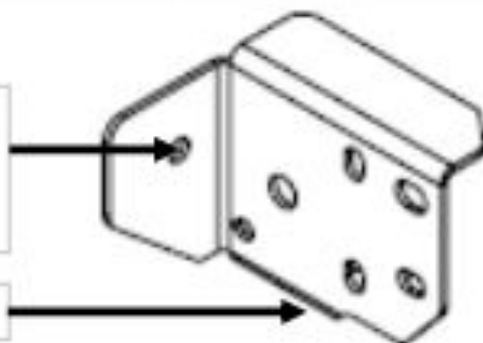

8 INSTALLATION OF THE REAR BUMPER

Mount the bumper as shown.

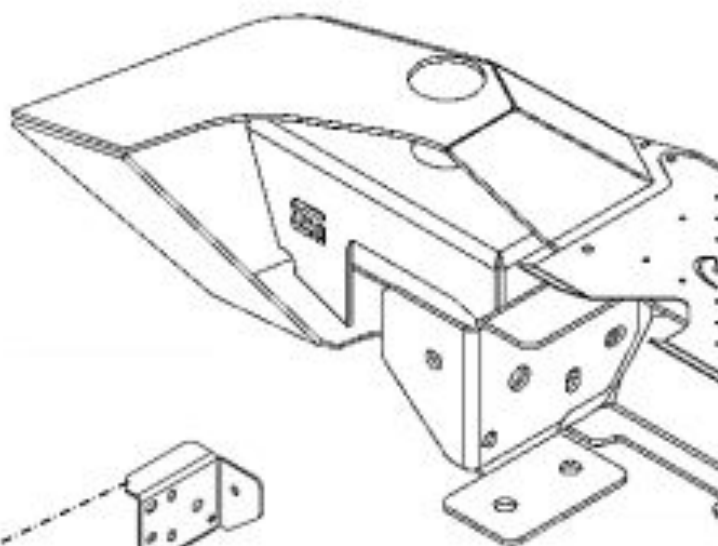
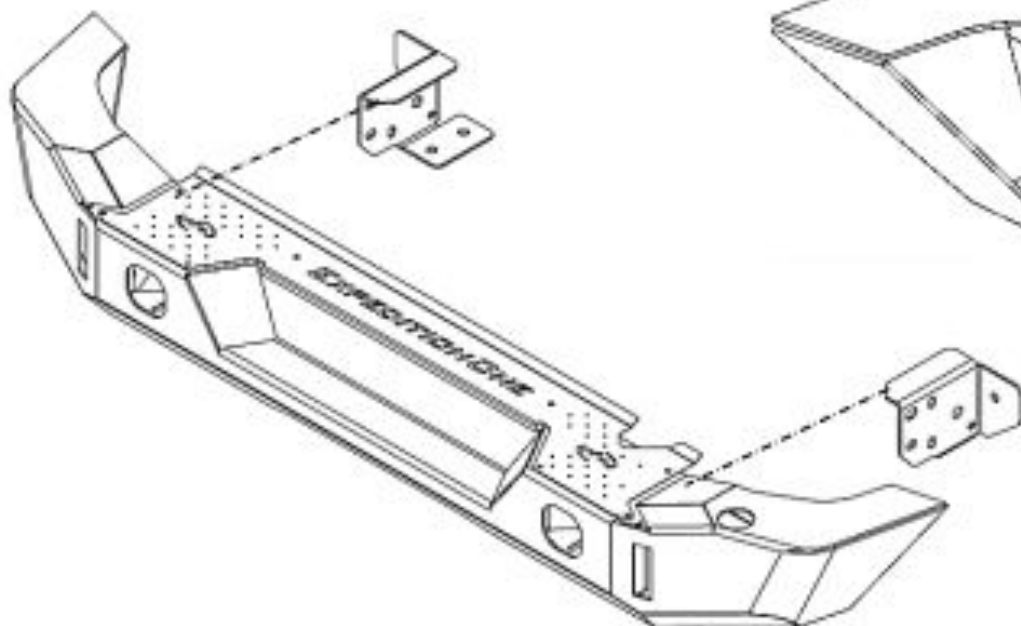

Center the bumper with the vehicle and align gaps between the body and bumper to your preference before mounting. Mount the front bumper using the supplied 1/2" hardware as shown below. Use the 5/8" hardware to mount the bumper to both the nut retainer and mounting bracket. Leave all hardware loose for adjustment.

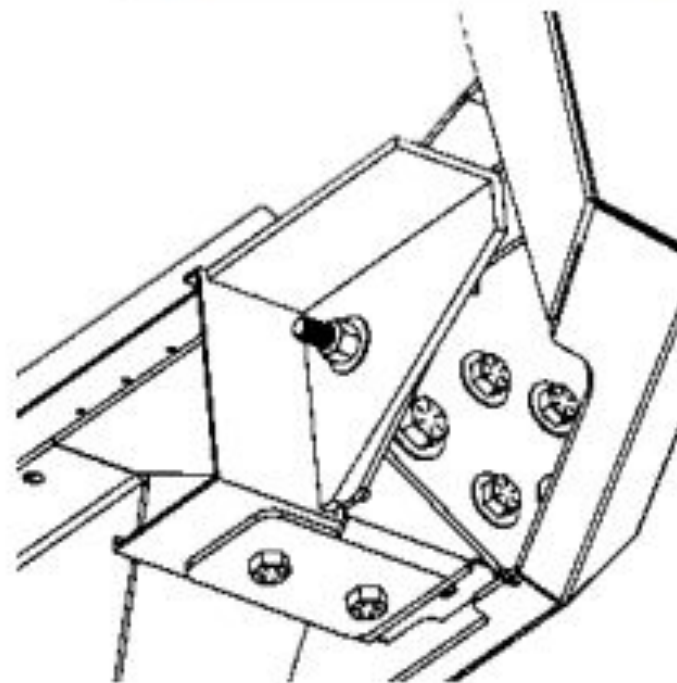
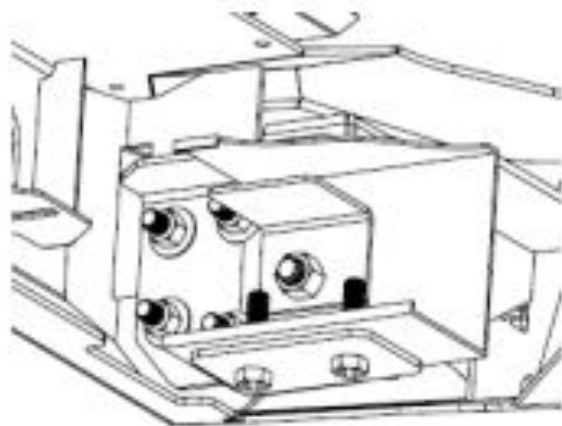
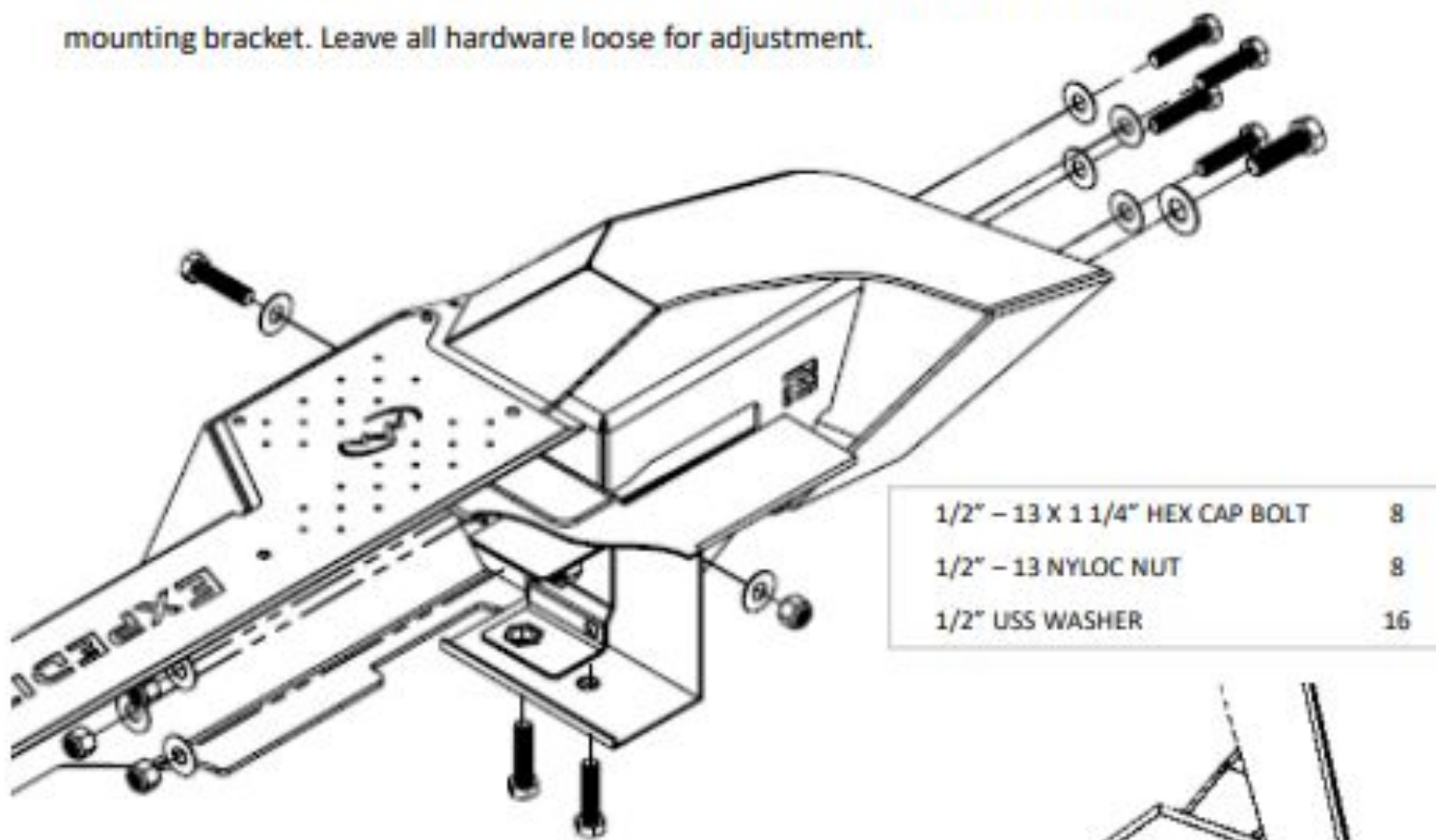

5/8" - 11 X 1 1/2" HEX CAP BOLT	2
5/8" USS WASHER	2

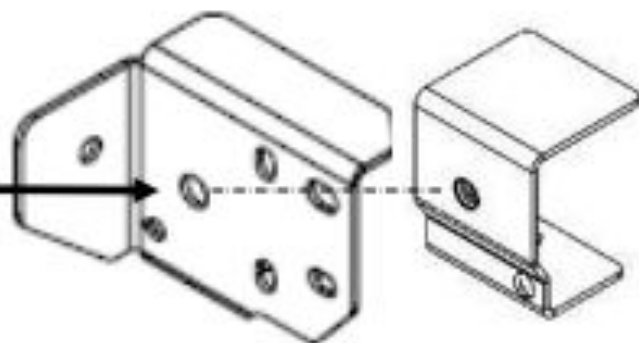

9 LICENSE PLATE RELOCATION OPTION

Assemble the license plate relocation as shown using the provided hardware.

NOTE - The license plate can be relocated to the tire or another place of your choosing. We do not provide any hardware or parts for the wiring.

BASE BUMPER SHOWN



RAPTOR MODELS - M14 HARDWARE*

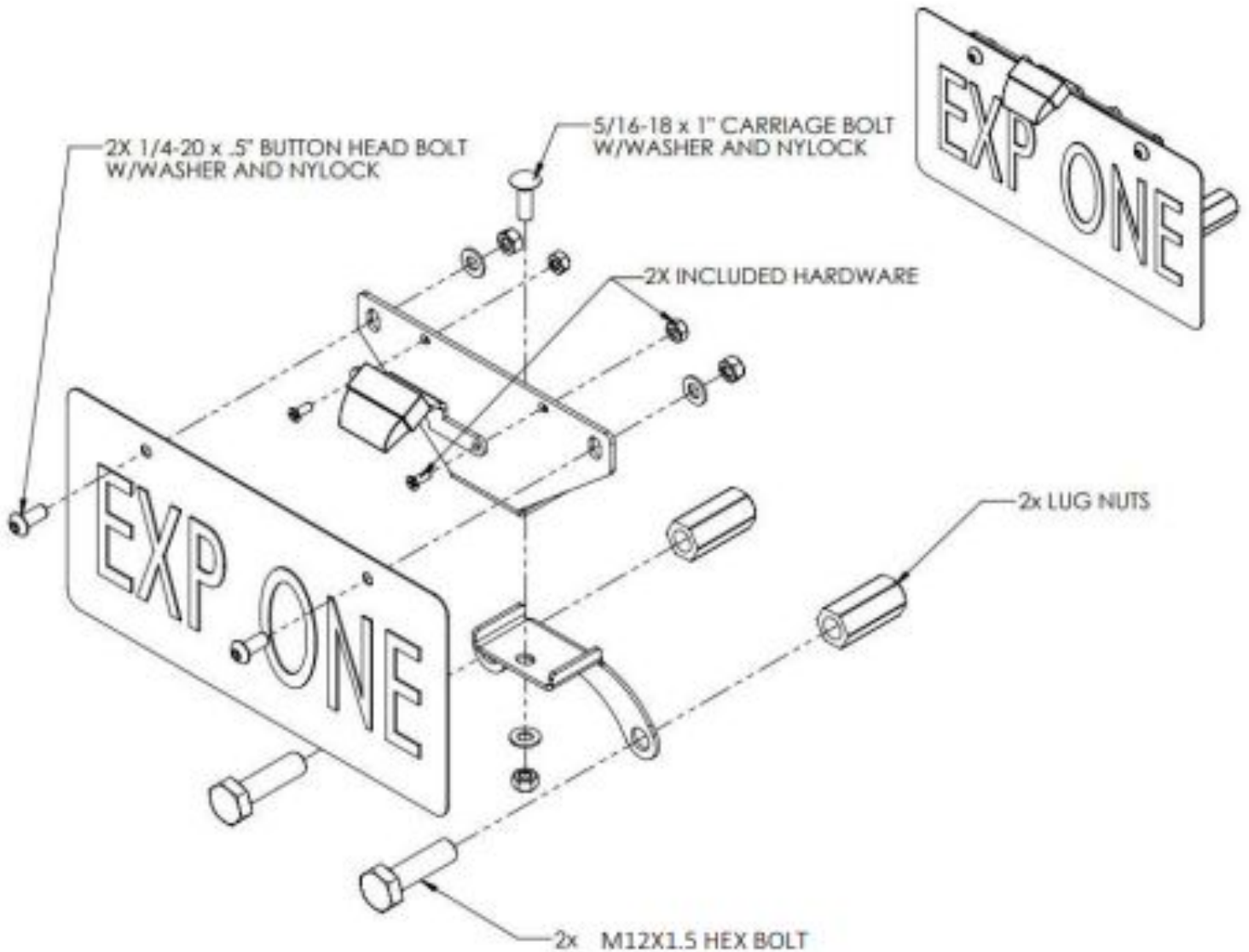

DSTC BUMPER SHOWN

Attach the OEM light to the provided bracket and mount inside the new bumper location with 1/4" hardware.

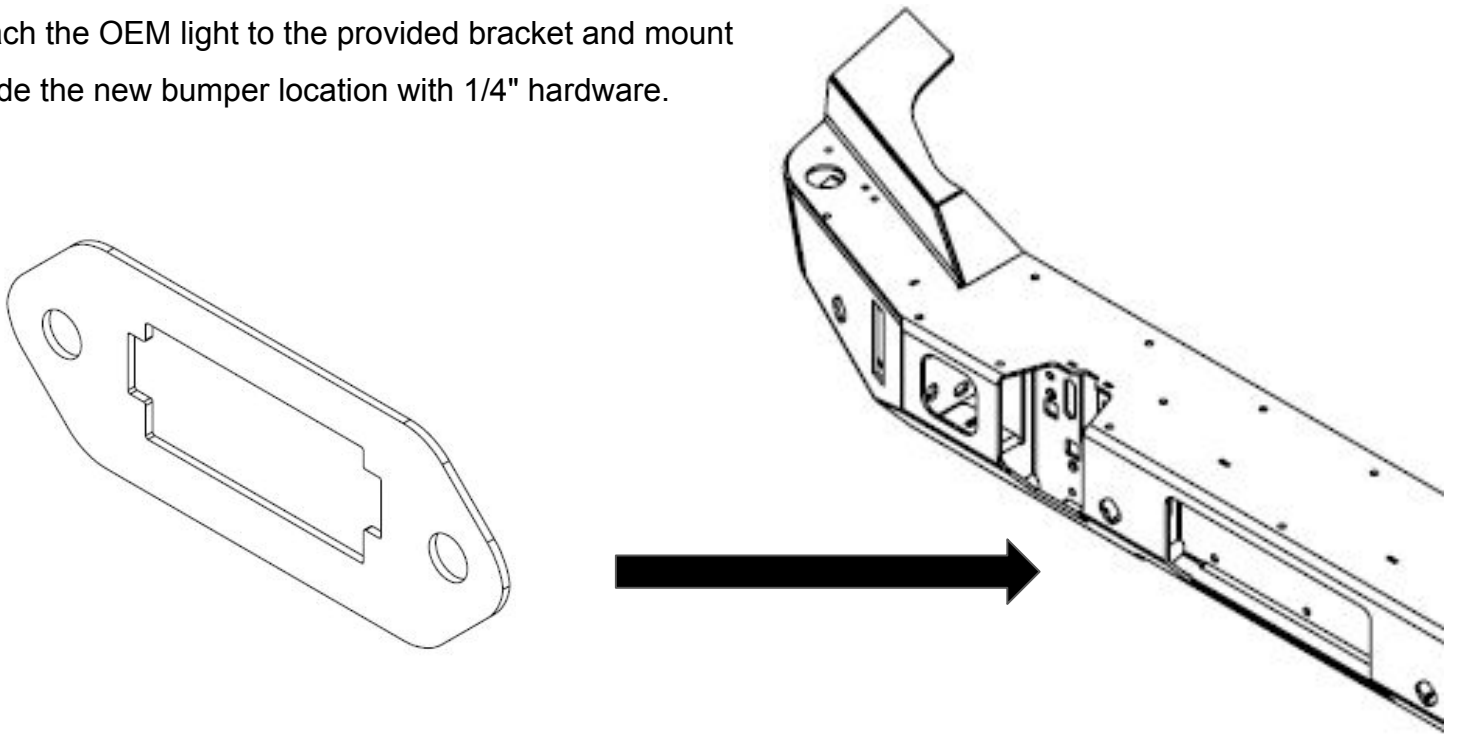

10 TIGHTEN ALL HARDWARE

Check that all hardware is tightened including all brackets and mounting locations.

11 RECONNECT WIRING HARNESS

Reconnect the parking sensor wiring harness to the vehicles electronics and secure all loose wiring. Check that everything is working and adjust if needed before driving on the road.

TIGHTEN ALL HARDWARE AFTER EVERYTHING IS INSTALLED ON THE VEHICLE. CHECK AND RETIGHTEN ALL HARDWARE AFTER THE FIRST 100 MILES AND AFTER OFF ROADING. CHECK REGULARLY AFTER EXTENDED OFFROAD USE