



2022 + TOYOTA TUNDRA SAM RACK



PLEASE READ ENTIRE GUIDE BEFORE INSTALLATION

Recommended that you read this entire install guide before installation. Check that all hardware is present before starting or scheduling an install. This guide is supplemental to mechanical knowledge and ability. Anyone not familiar with automotive installation should seek professional installation.

INSTALL GUIDE

IMPORTANT INFO/FAQ

INSTALLATION HELP

Please review terms and conditions for details

Recommended purchaser review Welcome Guide at time of purchase for details

Care & Maintenance and Install Guides available at www.exp-one.com/resources

We do our best to offer timely assistance with your installation questions however as most of our team members are primarily engaged in the manufacturing process and packaging processes, we do not currently offer a tech for on-demand calls and inquiries. For the more technical installs or installs that are time-sensitive in nature, we would recommend our customers seek out the services of professional shops with experience specific to aftermarket bumpers.. We are happy to make recommendations to you on shops familiar with our products in your area. We do our best to respond to installation questions within 24-48 hours of contact as much as possible. Long-distance problem assessment can be difficult, so photos and videos are often required for us to best assist you. We highly recommend your initial contact regarding installation questions include both close-up and full photos, detailed descriptions using our part descriptions as much as possible, and video. This enables us to better assist without having the ability to see the install difficulties directly and assist you as quickly as possible.

NOTE

Expedition One does not guarantee fitment with other aftermarket products, or reinstallation of take off OEM parts.

Expedition One is NOT RESPONSIBLE for damage to paint or powder coating, items assembled in error during installation or costs associated with install, and injury.

OEM manufacture model refreshes/updates, factory build location and suppliers may cause variations in fitment or installation and can not be verified, vehicle to vehicle .

EXPEDITION ONE
113 N. 700 W. BUILDING 5C BAY 1
OGDEN, UT 84404
INFO@EXPEDITIONONE.BIZ
801-627-2921 MON-FRI 0900-1700 MST

INSTALL LEVEL



- | | | |
|---------|-------|--|
| 1 STAR | ★ | EASY - No tools required |
| 2 STARS | ★★ | BASIC - Requires standard tools, basic mechanical knowledge and understanding |
| 3 STARS | ★★★ | MODERATE - Requires standard tools. Some drilling and/or cutting. |
| 4 STARS | ★★★★ | ADVANCED - Requires speciality tools. Drilling, cutting, and grinding required |
| 5 STARS | ★★★★★ | EXPERT - Professional installation recommended. |

We always recommend professional assistance when installing our vehicle products. Always follow safety precautions including the use of safety gear and devices.

IMPORTANT INFO/FAQ

LIGHT PODS + LIGHT BARS

To give you a wide range of options from various brands and designs, the light openings were designed to be as universal as possible. Not all mounts or designs will fit exactly and may require the use of shims, spacers, removal of housings or covers, different light manufacture mounts or hardware to mount, or drilling. Specific mounts or options if available will be listed at time of purchase and provided with hardware. Bolt-on light mounts or items will mount as per the instructions. It is recommended that lights be purchased with the rack in hand to gain the best fitment. We DO NOT manufacture the lights, provided wiring, or instructions on how to connect to the OEM harness. Seek professional installation on hybrid or electric vehicles

AFTERMARKET or OEM PRODUCTS

We DO NOT guarantee fitment or installation of any aftermarket, third party or OEM parts, accessories, or hardware. This includes items such as lighting, winches, skids, lifts, suspension, and accessory mounts. Access to all brands, manufactures and country of origin specific parts is limited or impossible during the product development stage and subsequent new or modified revisions of said products including OEM design changes or refreshes. It is recommended you have the product in hand and installed before modifying with other aftermarket parts. Consult other sources to gain any first hand knowledge of other products others have installed.

IMPORTANT INFO/FAQ

HARDWARE

Please review for details and installation. Figures or data may vary. Leave all accessible hardware loose for installation and tighten all hardware after everything is installed on the vehicle. Check and tighten all hardware after the first 100 miles and/or after off roading.

Some hardware locations do not require being tightened to spec due to there design, location or material attachment (including rubber, plastic, and aluminum). Over tightening may break or damage parts. Torque spec may vary, amounts listed are generic.

HARDWARE		TORQUE SPEC	
SIZE	SOCKET	GR5 / 8.8	GR8 / 10.9
#8	1/4"	X	
#10	5/16"		
1/4"	7/16"	6-8	9-10
5/16"	1/2"	13-14	18-20
3/8"	9/16"	23-26	33-37
7/16"	5/8"	37-41	52-58
1/2"	3/4"	57-64	80-90
9/16"	13/16"	82-91	115-129
5/8"	15/16"	112-118	159-180
3/4"	1-1/8"	200-223	282-315
1"	36MM	X	
M6	10MM	9-10	13-15
M8	13MM	22-24	32-35
M10	15MM	44-49	64-72
M12	18MM	76-83	112-123
M14	21MM	102-112	165



GRADE 5

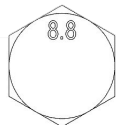



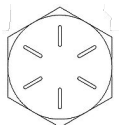



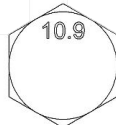







CLASS 8.8



GRADE 8



CLASS 10.9

TYPES OF HARDWARE		
		
HEX CAP BOLT	WASHER	NYLOC NUT
		
BUTTON HEAD BOLT	FENDER WASHER	HEX NUT
		
CARRIAGE BOLT	INTERNAL TOOTH	JAM NUT
		
SOCKET CAP BOLT	CLIP NUT	ACORN NUT
		
FLAT HEAD SCREW	RIVET NUT	COUPLING

NOTE

Extra hardware may be left over due to model or option specific items that may not be required for the install. OEM hardware may vary in style or socket size from shown.

TIGHTEN ALL HARDWARE AFTER EVERYTHING IS INSTALLED ON THE VEHICLE. CHECK AND TIGHTEN ALL HARDWARE AFTER THE FIRST 100 MILES AND AFTER OFF ROADING. CHECK REGULARLY

1 – FRONT FAIRING

Attach the provided weather striping to the underside of the air dam and trim to fit. Mount the air dam to the front load bar as shown (open end front facing) during assembly of the roof rack using the 5/16" hardware.

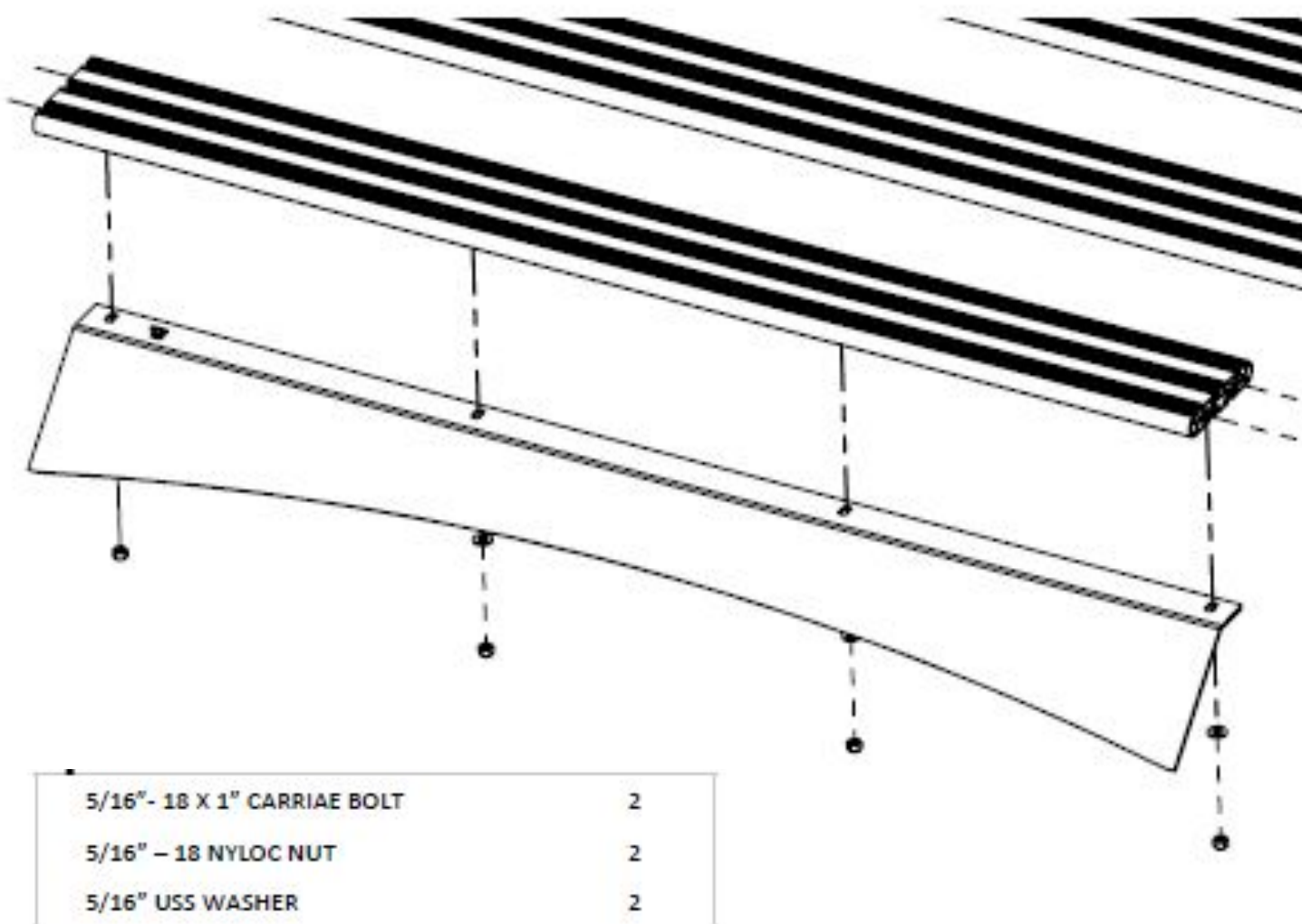

2 – RACK ASSEMBLY

Assemble the rack as shown. Start by attaching each side fascia to the load bars. Repeat this step for the other side, and do not tighten hardware. Bar locations may vary depending on OEM options, bars purchased, and personal preference. The ends of each section must have a load bar attached.

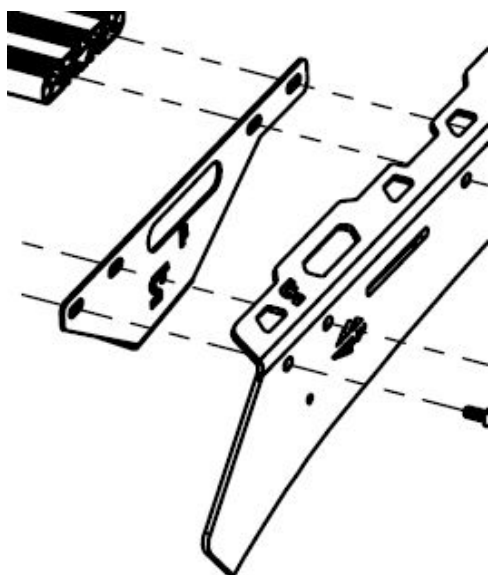
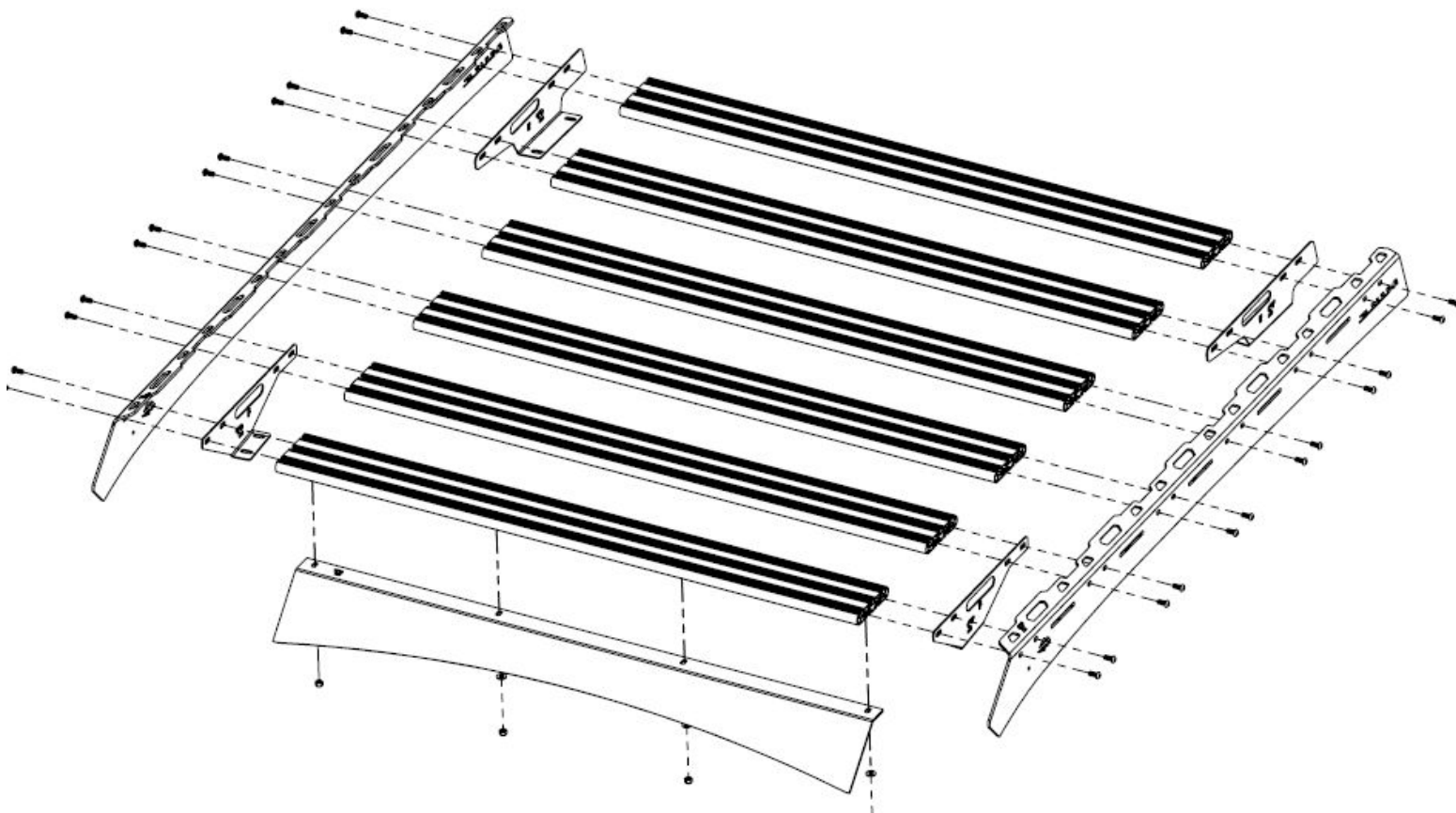

FRONT DRIVER SIDE EXAMPLE

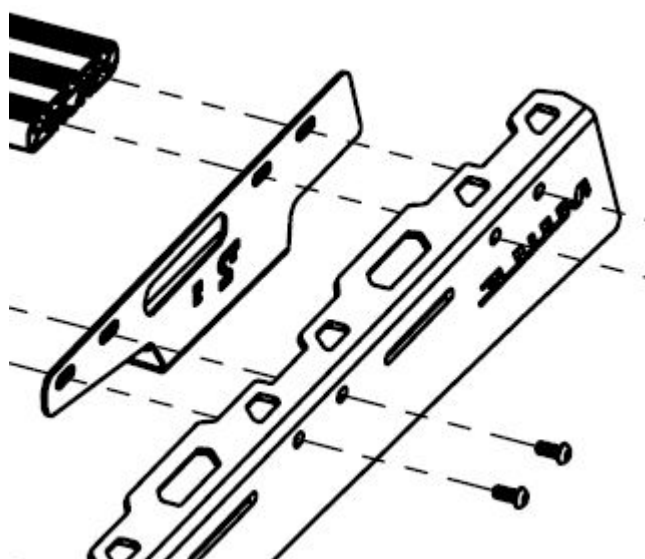

REAR DRIVER SIDE EXAMPLE

LOAD BAR SPACER

Insert the spacer between the side fascia and load bars for non mount bracket locations

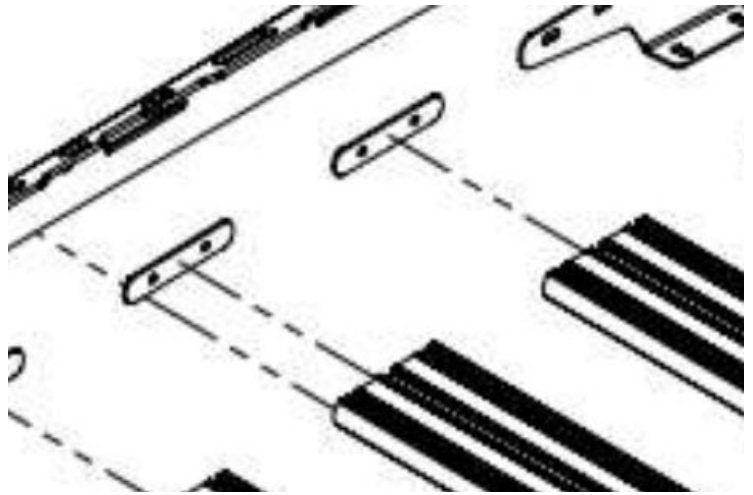

LOCATION WITH NO LOAD BAR

Attach the mount as shown using the provided 5/16" hardware. If the location doesn't mount to anything leave empty

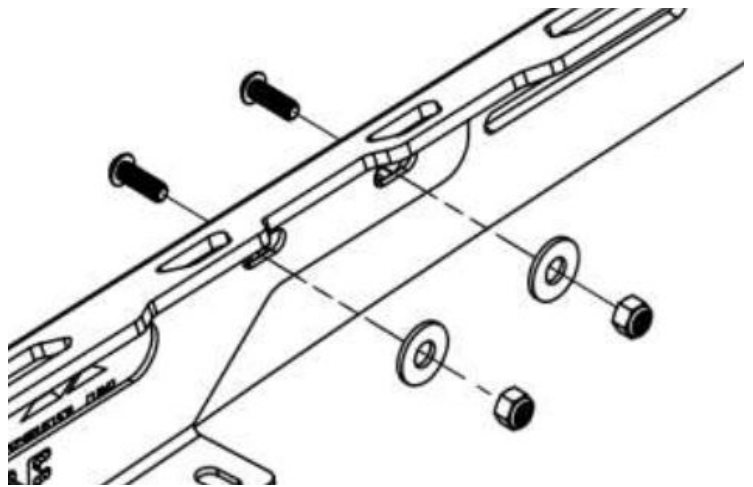

3 – ROOF MOUNT DRILLING

Use the provided templates to mark the locations of the mounts and holes to drill on each side

Recommended you drop the headliner at each location to double check for wiring and airbag hardware before drilling.

With the hole locations marked, drill each hole to roughly 3/8" in size. Next, add some caulk sealant to riv nut as shown. (this will help seal the nut into the roof from the elements).with two wrenches, begin twisting your riv nut down into the roof until you feel it 'sit' snug. Then go ahead and hold the bottom wrench in place and twist off the long bolt. Your riv nut should remain firmly in place. Continue this with the other drilled hole and then repeat these steps for the other rear side of vehicle. Cover the mount locations with the provided foam strip and mount the brackets using the provided hardware.



4 – MOUNTING

Remove the OEM roof rails sides if equipped. Locate the mount areas by removing the painted sticker. Place the provided foam tape of the locations and punch out the holes.



Mount the rack into position on top of the spacer locations and align with each bracket. Use the provided 1/4" hardware. Use the provided spacers to rest the brackets on above the roof seams. Use extra spacers to level and adjust the roof rack as needed. Square up the rack and tighten all hardware once completed.

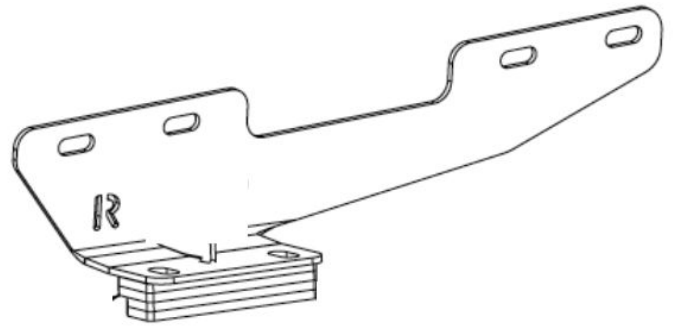

SPACER EXAMPLE

TIGHTEN ALL HARDWARE AFTER EVERYTHING IS INSTALLED ON THE VEHICLE. CHECK AND RETIGHTEN ALL HARDWARE AFTER THE FIRST 100 MILES OR AFTER OFF ROADING. CHECK REGULARLY AFTER EXTENDED OFFROAD USE