



# TOYOTA TACOMA 2024+ FRONT BUMPER



## **PLEASE READ ENTIRE GUIDE BEFORE INSTALLATION**

Recommended that you read this entire install guide before installation. Check that all hardware is present before starting or scheduling an install. This guide is supplemental to mechanical knowledge and ability. Anyone not familiar with automotive installation should seek professional installation.

# IMPORTANT INFO/FAQ

---

## INSTALLATION HELP

Please review terms and conditions for details

Recommended purchaser review Welcome Guide at time of purchase for details

Care & Maintenance and Install Guides available at [www.exp-one.com/resources](http://www.exp-one.com/resources)

We do our best to offer timely assistance with your installation questions however as most of our team members are primarily engaged in the manufacturing process and packaging processes, we do not currently offer a tech for on-demand calls and inquiries. For the more technical installs or installs that are time-sensitive in nature, we would recommend our customers seek out the services of professional shops with experience specific to aftermarket bumpers.. We are happy to make recommendations to you on shops familiar with our products in your area. We do our best to respond to installation questions within 24-48 hours of contact as much as possible. Long-distance problem assessment can be difficult, so photos and videos are often required for us to best assist you. We highly recommend your initial contact regarding installation questions include both close-up and full photos, detailed descriptions using our part descriptions as much as possible, and video. This enables us to better assist without having the ability to see the install difficulties directly and assist you as quickly as possible.

## NOTE

Expedition One does not guarantee fitment with other aftermarket products, or reinstallation of take off OEM parts.

Expedition One is NOT RESPONSIBLE for damage to paint or powder coating, items assembled in error during installation or costs associated with install, and injury.

OEM manufacture model refreshes/updates, factory build location and suppliers may cause variations in fitment or installation and can not be verified, vehicle to vehicle .

EXPEDITION ONE  
113 N. 700 W. BUILDING 5C BAY 1  
OGDEN, UT 84404  
INFO@EXPEDITIONONE.BIZ  
801-627-2921 MON-FRI 0900-1700 MST

## INSTALL LEVEL



- |         |       |  |
|---------|-------|--|
| 1 STAR  | ★     | EASY - No tools required   |
| 2 STARS | ★★    | BASIC - Requires standard tools, basic mechanical knowledge and understanding  |
| 3 STARS | ★★★   | MODERATE - Requires standard tools. Some drilling and/or cutting.              |
| 4 STARS | ★★★★  | ADVANCED - Requires speciality tools. Drilling, cutting, and grinding required |
| 5 STARS | ★★★★★ | EXPERT - Professional installation recommended.                                |

We always recommend professional assistance when installing our vehicle products. Always follow safety precautions including the use of safety gear and devices.

# IMPORTANT INFO/FAQ

---

## WINCHES

We use the most common bolt patterning but cannot guarantee your particular winch will fit. Because there are so many different brands on the market for winches, we typically recommend you wait until you have your bumper in-hand and ideally even installed to have specific measurements for best fit for your particular application. Integrated and Non-Integrated solenoid fitment varies by vehicle, model, and engine. Non-integrated solenoids will need to be relocated to an open location within the bumper, engine bay, or other open location. We DO NOT provide mounts or instruction for relocation of the solenoid. Most bumpers use a foot forward mount and will require the winch to be clocked ( see winch manufacture for details). Winch plates or direct mounting locations will be provided with the bumper, see install guide for details. See winch manufacture for hardware, associated parts, or fairleads. . We DO NOT manufacture the winch, provided wiring, or instructions on how to connect to the vehicles power. Seek professional installation on hybrid or electric vehicles

## LIGHT PORTS + LIGHT BARS

To give you a wide range of options from various brands and designs, the light ports were designed to be as universal as possible. Not all mounts or designs will fit exactly and may require the use of shims, spacers, removal of housings or covers, different light manufacture mounts or hardware to mount. Reuse of OEM light is limited to select bumpers and will come with provided hardware to reinstall. Specific mounts or options if available will be listed at time of purchase and provided with hardware. Bolt-on light ports or mounts will mount as per the instructions. It is recommended that lights be purchased with the bumper in hand to gain the best fitment. We DO NOT manufacture the lights, provided wiring, or instructions on how to connect to the OEM harness. Seek professional installation on hybrid or electric vehicles\

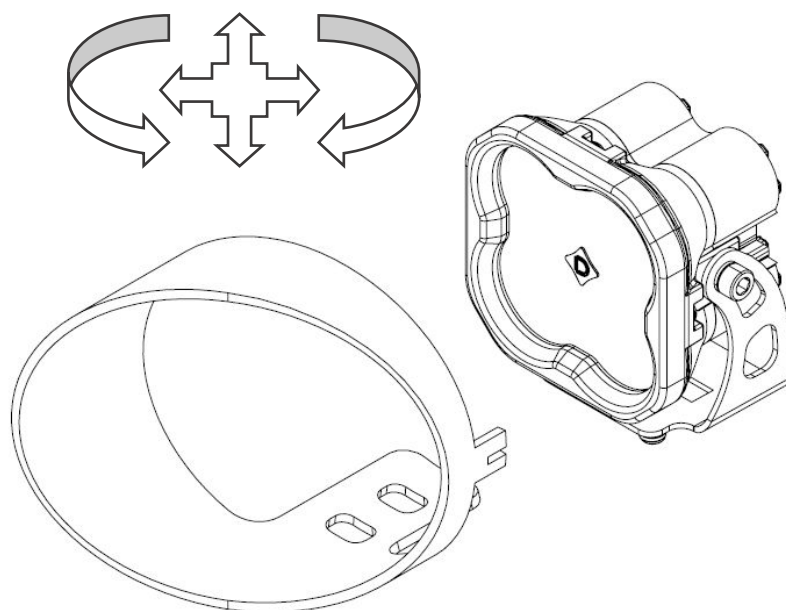

## EXAMPLE SHOWN - LIGHT PORTS WILL VARY

## AFTERMARKET or OEM PRODUCTS

We DO NOT guarantee fitment or installation of any aftermarket, third party or OEM parts, accessories, or hardware. This includes items such as lighting, winches, skids, lifts, suspension, and accessory mounts. Access to all brands, manufactures and country of origin specific parts is limited or impossible during the product development stage and subsequent new or modified revisions of said products including OEM design changes or refreshes. It is recommended you have the product in hand and installed before modifying with other aftermarket parts. Consult other sources to gain any first hand knowledge of other products others have installed.

# IMPORTANT INFO/FAQ

## HARDWARE

Please review for details and installation. Figures or data may vary. Leave all accessible hardware loose for installation and tighten all hardware after everything is installed on the vehicle. Check and tighten all hardware after the first 100 miles and/or after off roading.

**Some hardware locations do not require being tightened to spec due to there design, location or material attachment (including rubber, plastic, and aluminum). Over tightening may break or damage parts. Torque spec may vary, amounts listed are generic.**

HARDWARE		TORQUE SPEC	
SIZE	SOCKET	GR5 / 8.8	GR8 / 10.9
#8	1/4"	X	
#10	5/16"		
1/4"	7/16"	6-8	9-10
5/16"	1/2"	13-14	18-20
3/8"	9/16"	23-26	33-37
7/16"	5/8"	37-41	52-58
1/2"	3/4"	57-64	80-90
9/16"	13/16"	82-91	115-129
5/8"	15/16"	112-118	159-180
3/4"	1-1/8"	200-223	282-315
1"	36MM	X	
M6	10MM	9-10	13-15
M8	13MM	22-24	32-35
M10	15MM	44-49	64-72
M12	18MM	76-83	112-123
M14	21MM	102-112	165

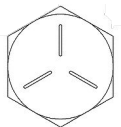

**GRADE 5**

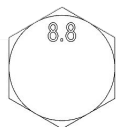



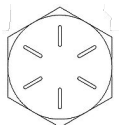



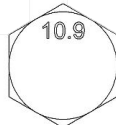







**CLASS 8.8**



**GRADE 8**

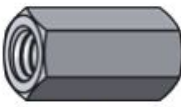

**CLASS 10.9**

TYPES OF HARDWARE		
		
HEX CAP BOLT	WASHER	NYLOC NUT
		
BUTTON HEAD BOLT	FENDER WASHER	HEX NUT
		
CARRIAGE BOLT	INTERNAL TOOTH	JAM NUT
		
SOCKET CAP BOLT	CLIP NUT	ACORN NUT
		
FLAT HEAD SCREW	RIVET NUT	COUPLING

### NOTE

Extra hardware may be left over due to model or option specific items that may not be required for the install. OEM hardware may vary in style or socket size from shown.

**TIGHTEN ALL HARDWARE AFTER EVERYTHING IS INSTALLED ON THE VEHICLE. CHECK AND TIGHTEN ALL HARDWARE AFTER THE FIRST 100 MILES AND AFTER OFF ROADING. CHECK REGULARLY**

# HARDWARE

---

1/4" – 20 X 3/4" BUTTON HEAD	3
1/4" – 20 X 3/4" HEX CAP	16
1/4" – 20 NYLOC NUT	19
1/4" WASHER	35
5/16" - 18 X 3/4" HEX CAP	8
5/16" - 18 X 1" CARRIAGE	9
5/16" - 18 NYLOC NUT	9
5/16" - 18 CLIP NUT	8
5/16" WASHER	17
3/8" - 16 X 3/4" BUTTON HEAD	2
3/8" - 16 X 1-1/4" HEX CAP	16
3/8" - 16 NYLOC NUT	16
3/8" - 16 CLIP NUT	2
3/8" WASHER	32
1/2" - 13 X 1-1/4" HEX CAP	2
1/2" - 13 X 4" HEX CAP	2
1/2" - 13 X 1" CARRIAGE	6
1/2" - 13 NYLOC NUT	10
1/2" WASHER	14
M6 x 1.0 - 25 HEX CAP BOLT	4
SENSOR COVER	1
SENSOR BEZEL	4

# HARDWARE

WINCH MOUNT

1

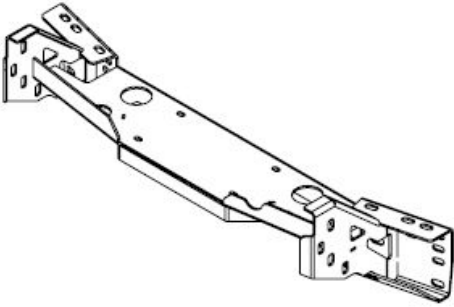

FRAME MOUNT INNER

2

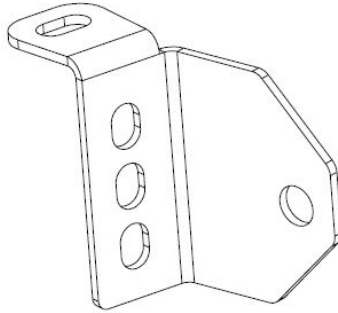

FRAME MOUNT OUTER

2

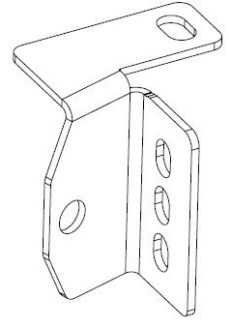

FILLER PLATE

1

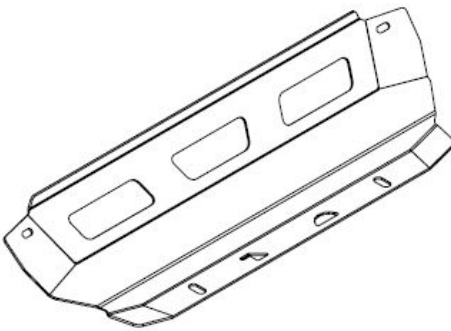

FRAME SPACER

2

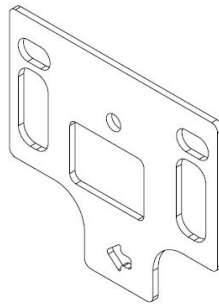

OEM FOG BRACKET

2

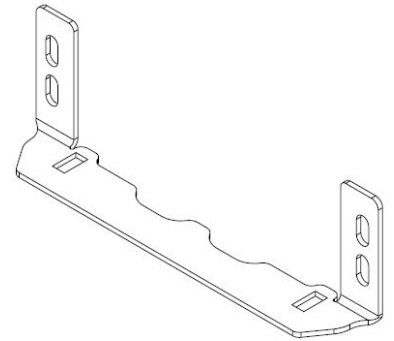

ACC SENSOR BRACKET

1

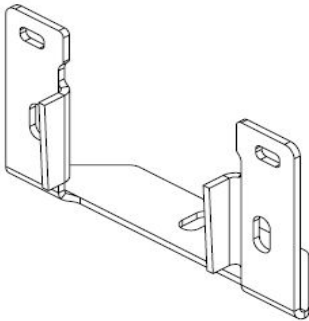

LIGHT BAR BRACKET

2

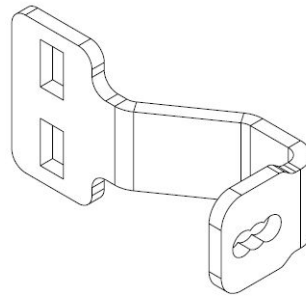

GRILLE SHUTTER FRAME

1

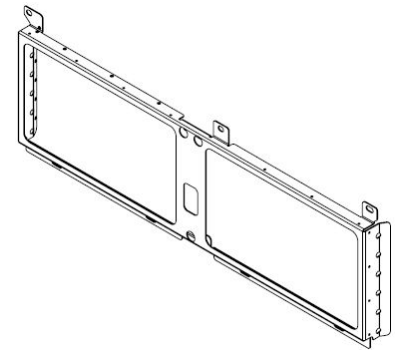

GRILLE BOTTOM BRACKET

2

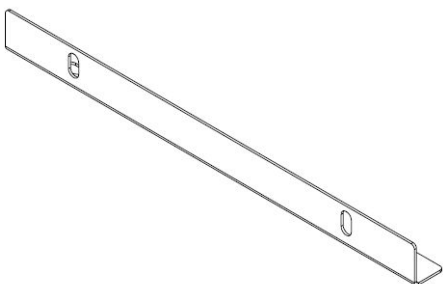

GRILLE L-BRACKET

4

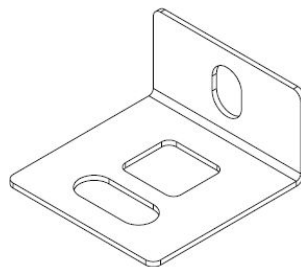

SHUTTER MOUNT BRACKET

2

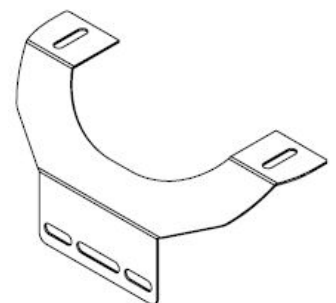

## OPTIONAL PURCHASE PARTS

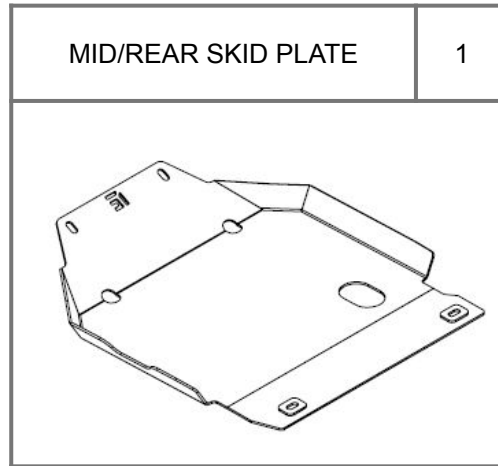
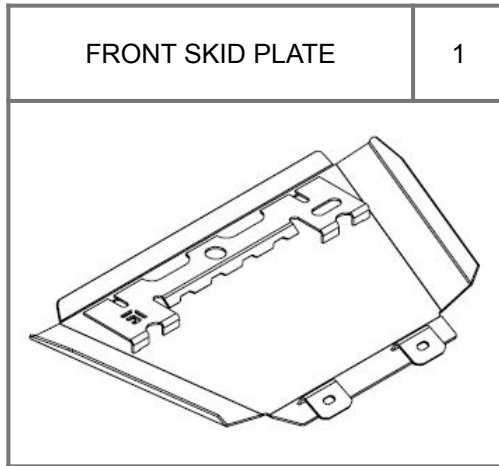

# 1 – BUMPER REMOVAL

Remove the entire front fascia as shown from fenders, under the hood, and underneath. Disconnect all wiring, lights and sensors. Check for any other connections or hardware before removing the bumper. Save hardware for reinstallation.



## 2 – BUMPER REMOVAL

Remove the grille brace. Undo the clips hold the bumper to the shroud as shown. Remove the cross frame by unbolting the assembly at the frame and bumper side wings (located behind the arrow below). Save hardware for reuse.



### 3 – REINFORCEMENT BRACKET INSTALLATION

Attach the provided reinforcement brackets using 1/2" hardware tab Leave hardware loose for adjustment.

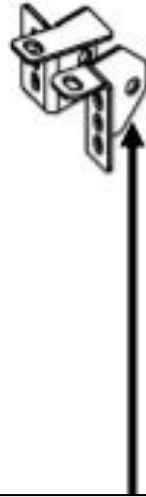

1/2" - 13 X 4" HEX CAP	2
1/2" - 13 NYLOC NUT	2
1/2" WASHER	4

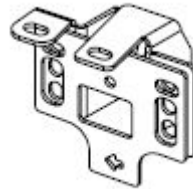

Place the provided space mount into the frame end as shown. Use the provided spacers on the outside edges when mounting the winch mount in the next step.



## 4 – REINFORCEMENT BRACKET INSTALLATION

Attach the provided reinforcement brackets using 3/8" hardware tab Leave hardware loose for adjustment.

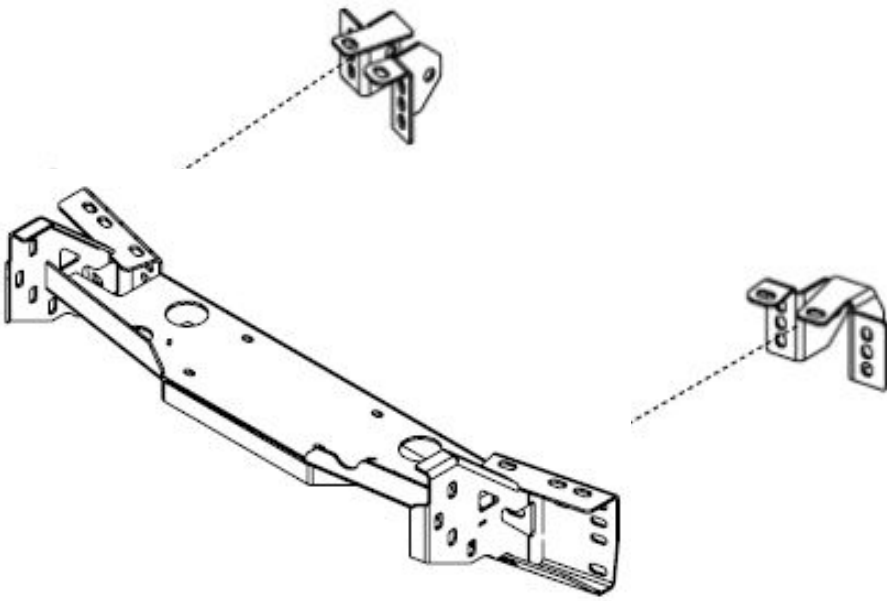

EXAMPLE SHOWN

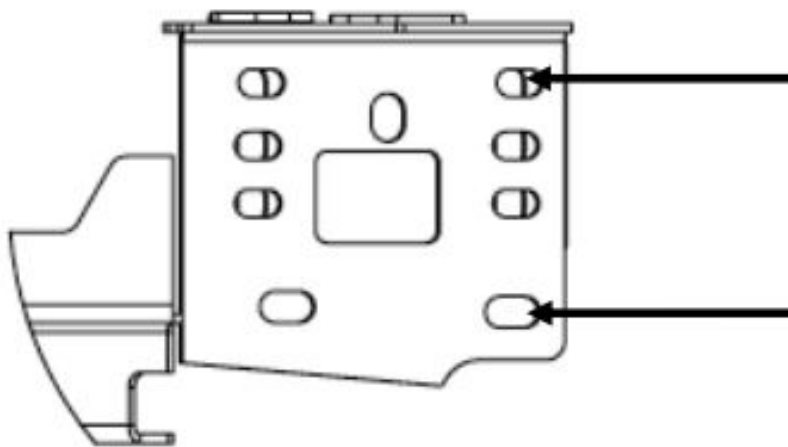

3/8" - 16 X 1-1/4" HEX CAP	12
3/8" - 16 NYLOC NUT	12
3/8" WASHER	24

OEM HARDWARE	4
--------------	---

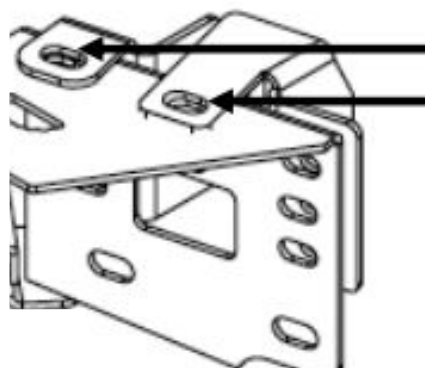

3/8" - 16 X 1-1/4" HEX CAP	4
3/8" - 16 NYLOC NUT	4
3/8" WASHER	8

EXAMPLE SHOWN

## 5 – WINCH INSTALLATION

Mount the winch at this time using the winch manufacture provided hardware. This will mount directly to the winch mount. Adjust as needed. see winch section for details. Skip if no winch is to be installed. Some trimming or removal of cross frame tabs or mounts may be required. Check fitment again once OEM bumper trimming and grille shutter are relocated before mounting the bumper

## 6 – WIRE LOOM REMOVAL

Unclip the wiring loom from the grille. Disconnect the parking sensors from the bezels. Be care to not break any clips or parts of the bezel as they will be reused in the new bumper. Unplug and remove the fog lights grille shutter assembly and ACC at this time. Note the position of sensors and plug locations for correct reinstallation position later.



## 7 – BUMPER TRIMMING

Trim the bumper as shown in the following pages, make minimum cuts and fit check if needed.. Extra may be required once the bumper is fitted to allow for body and frame flex or variations in OEM product and manufacturing. Mask the cutting line with tape for a guide line and to protect the edge during cutting.



The center cut line should follow the transition edge as shown. Save what bracing you can for rigidity.

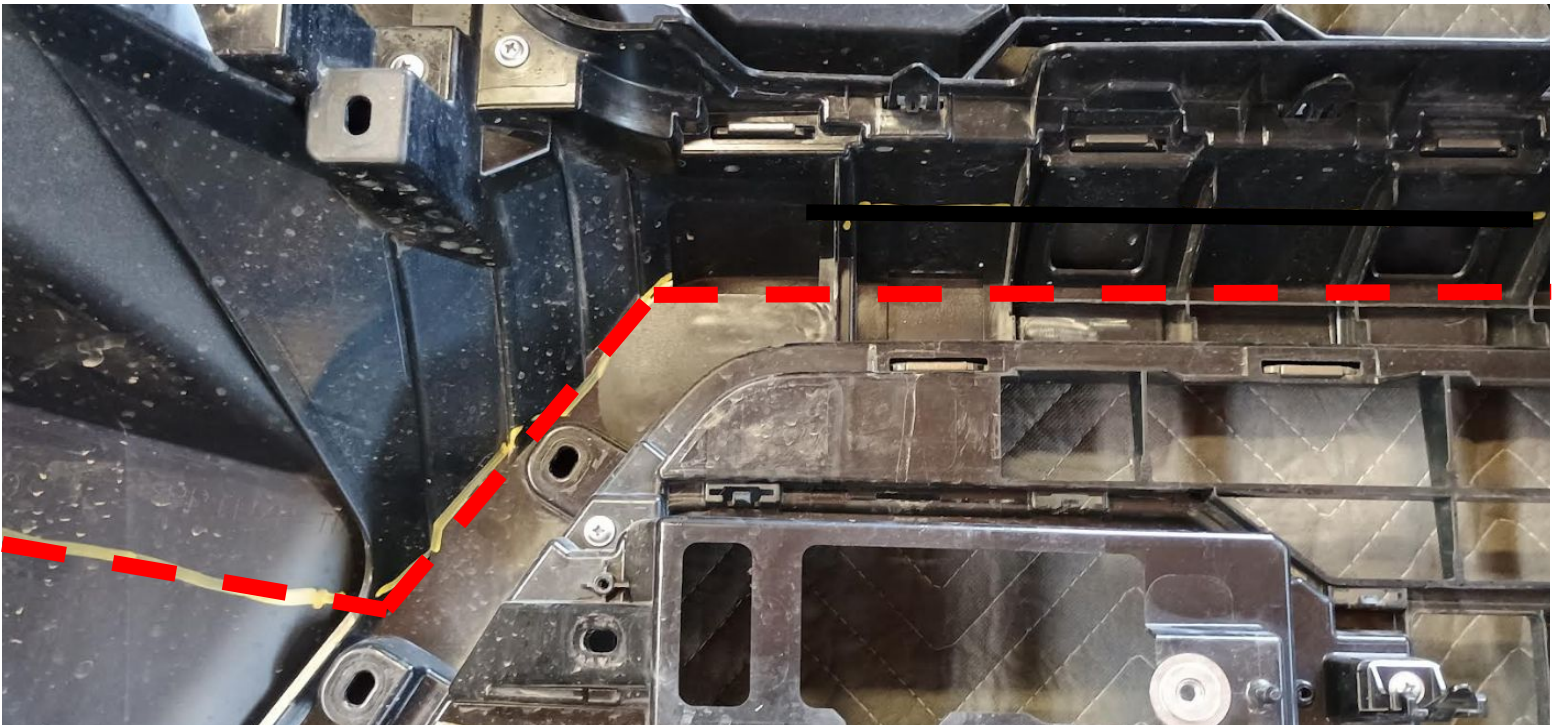
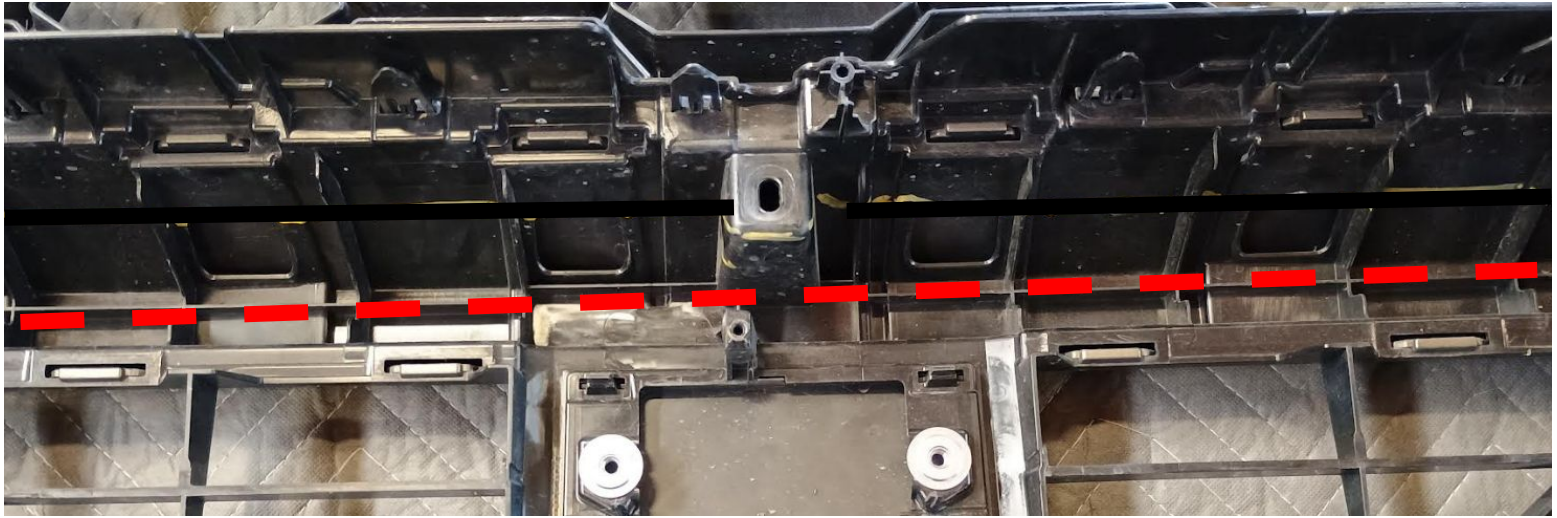
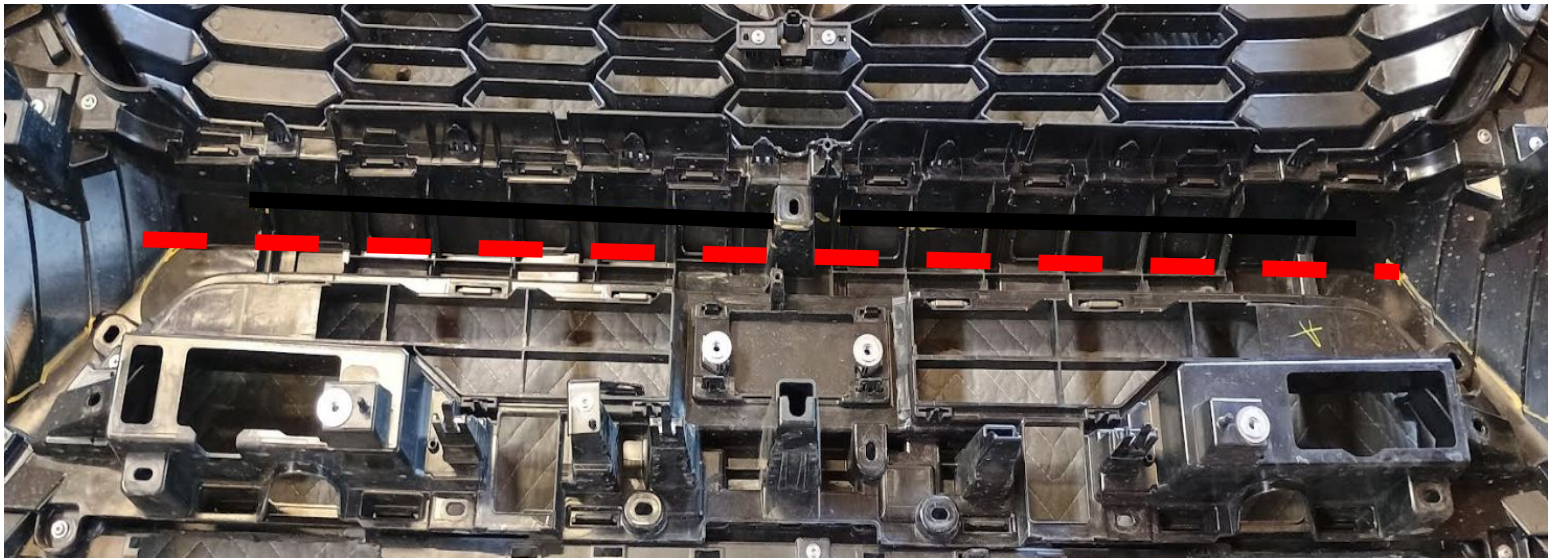

The sides should follow a parallel line about 1 1/2" below the vent inlet bottom plain. Angle the cut once past the vent area to encompass the clip to help hold the outer fender

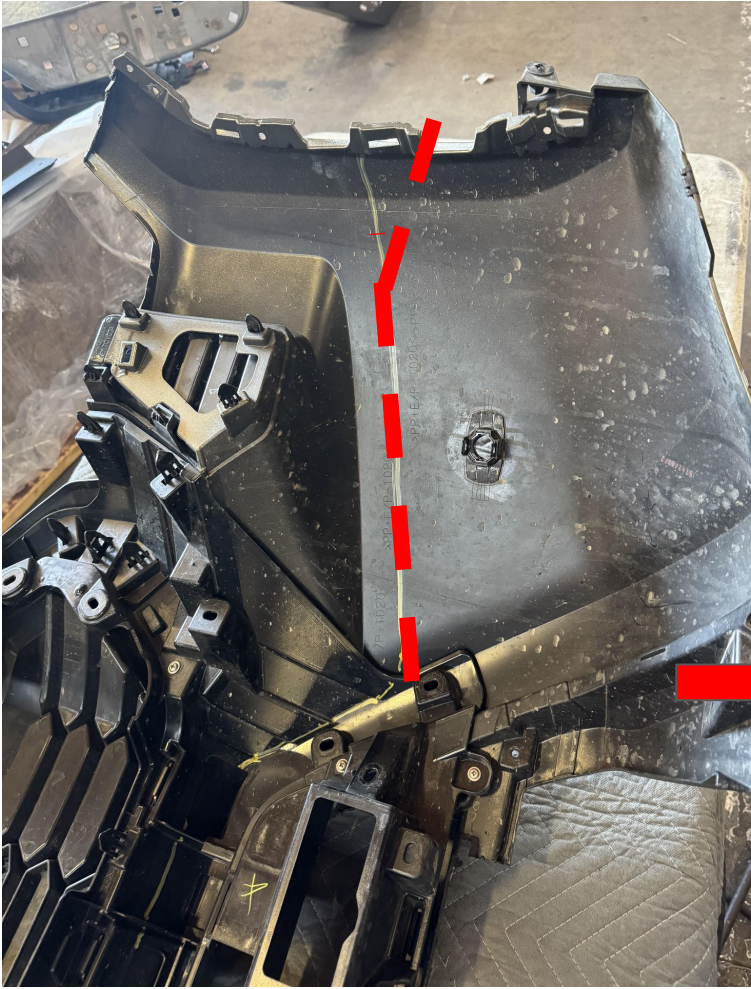

Trim the vent section to remove the outer edge and fins. Cut remaining fender trim to match the bumper cut line on the bottom.

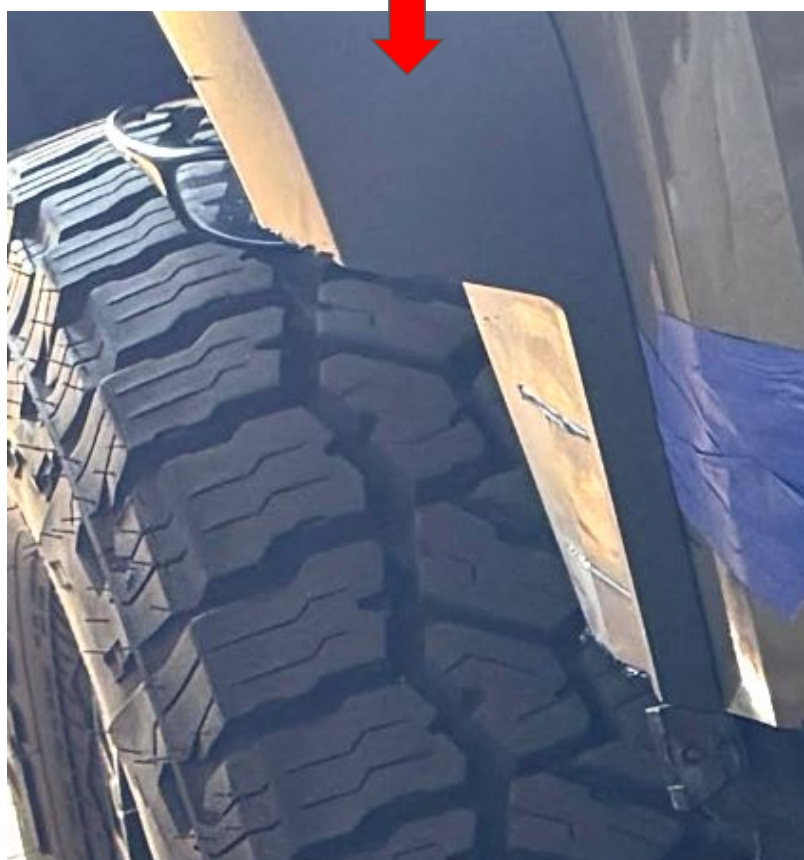
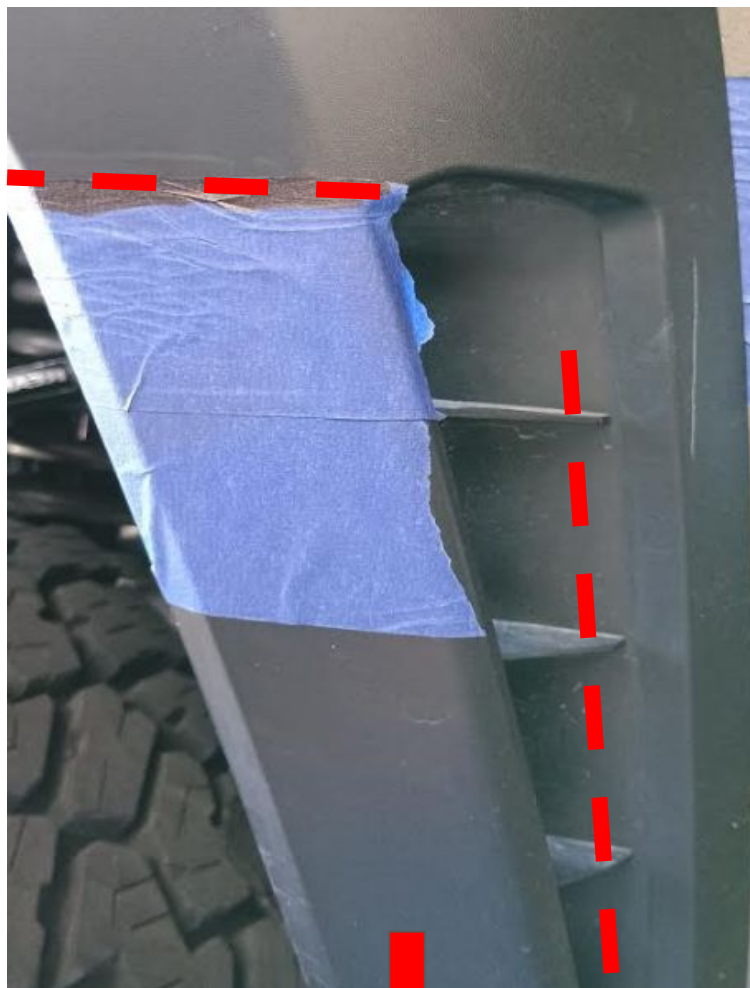

## 8 – GRILLE SHUTTER RELOCATION

Remove and disassemble the grille shutter as shown for transfer to the provided shutter frame. The outer ends of the 6 shutters will be removed the original housing and relocated while the center and motor area will be cut and shortened to clear the new bumper. Relocate or move wiring as need for cutting  
DO NOT cut out the motor location, the outer ends of the fins or the connecting pivots of the system.

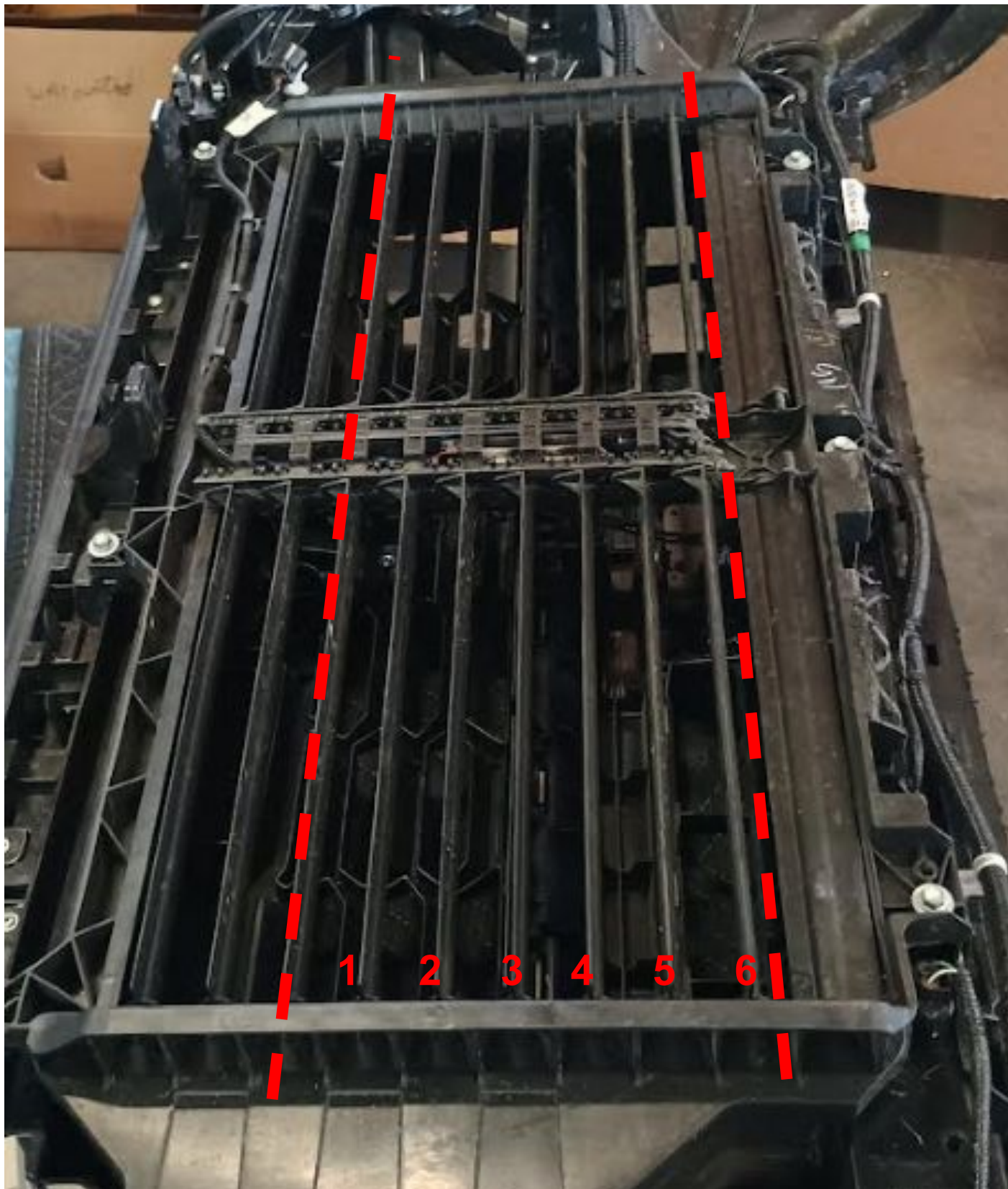

# REFERENCE

Top Arrow - End retains the some of the frame and support but loses the shutter

Middle Arrow - Motor and its mounting remain in place

Bottom Arrow - Fork type end in left in place.

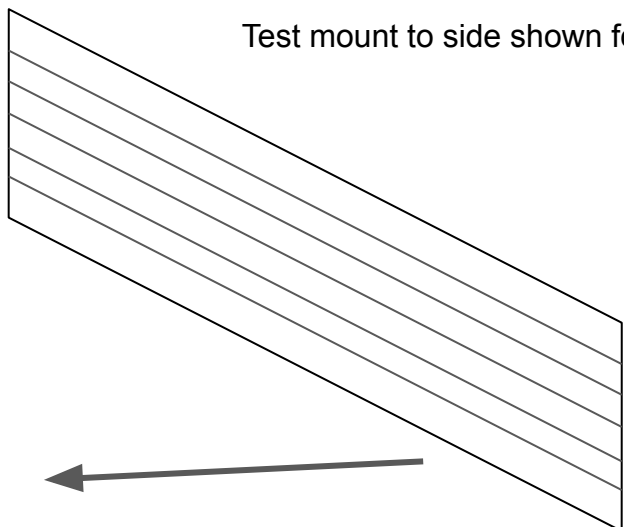
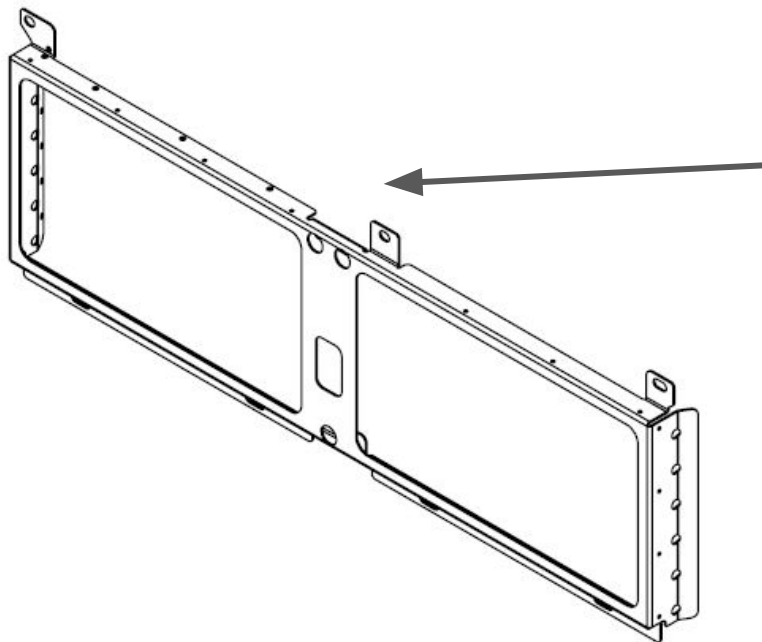
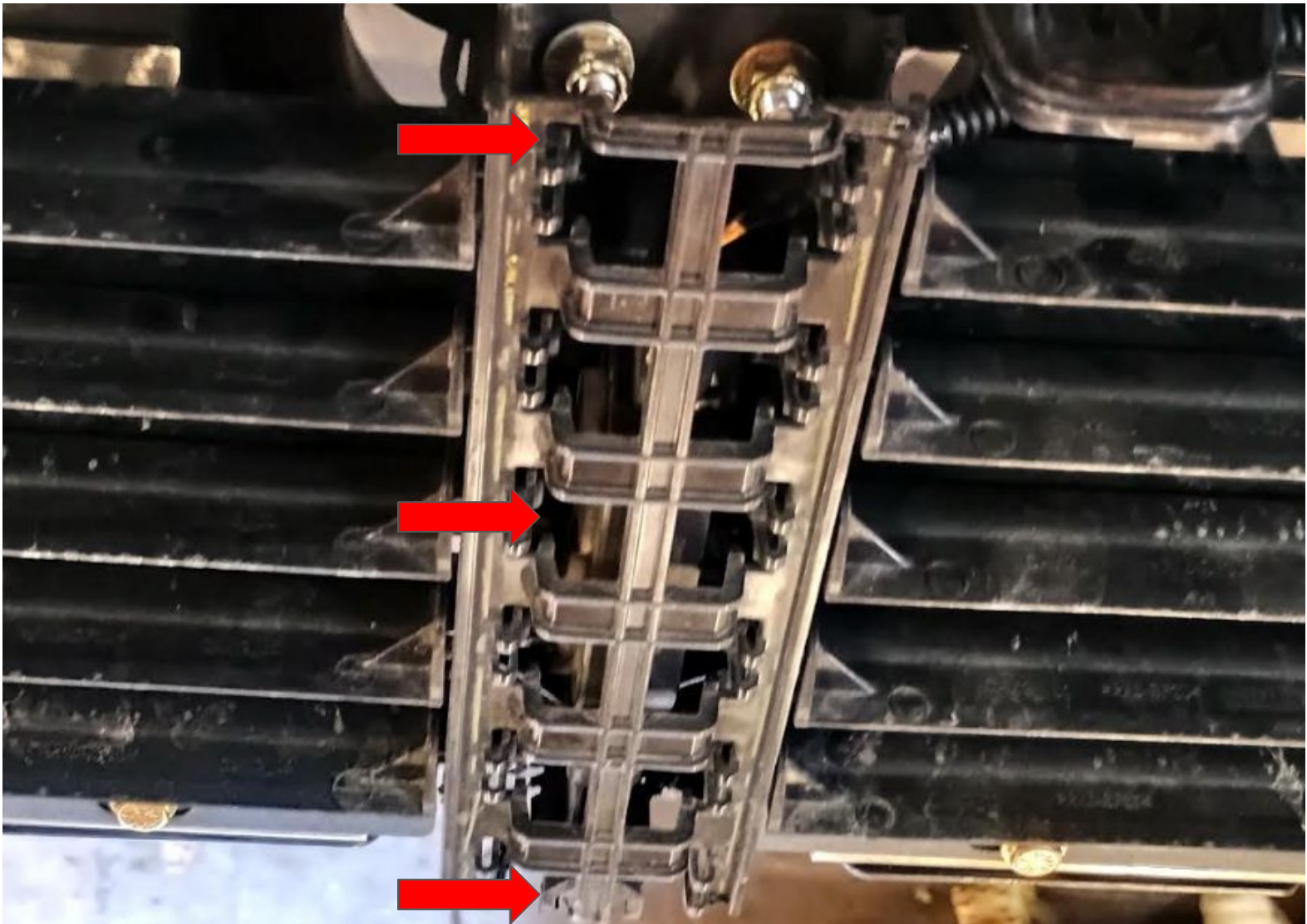

Test mount to side shown for next step

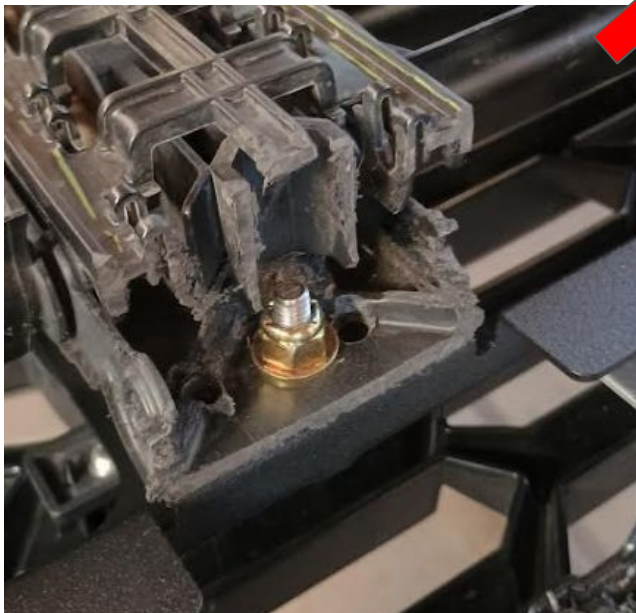
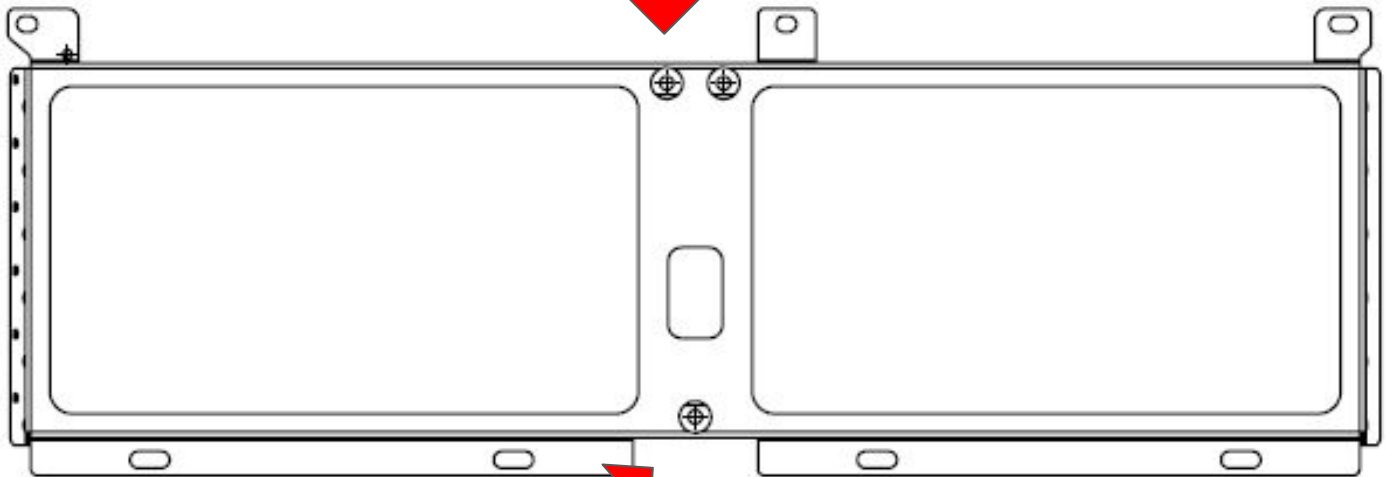

Center within the dimensions of the frame and install the outer ends into place, trim any access if needed. Mark the locations of the center holes and drill (avoid wiring and motor) mounting using 1/4" provided hardware.

1/4" - 20 X 3/4" BUTTON HEAD	3
1/4" - 20 NYLOC NUT	3
1/4" WASHER	3

Place the bottom bracket as shown and mark 3 bottom hole locations. Drill to fit the provided 1/4" hardware. Repeat for other side and bolt in place.

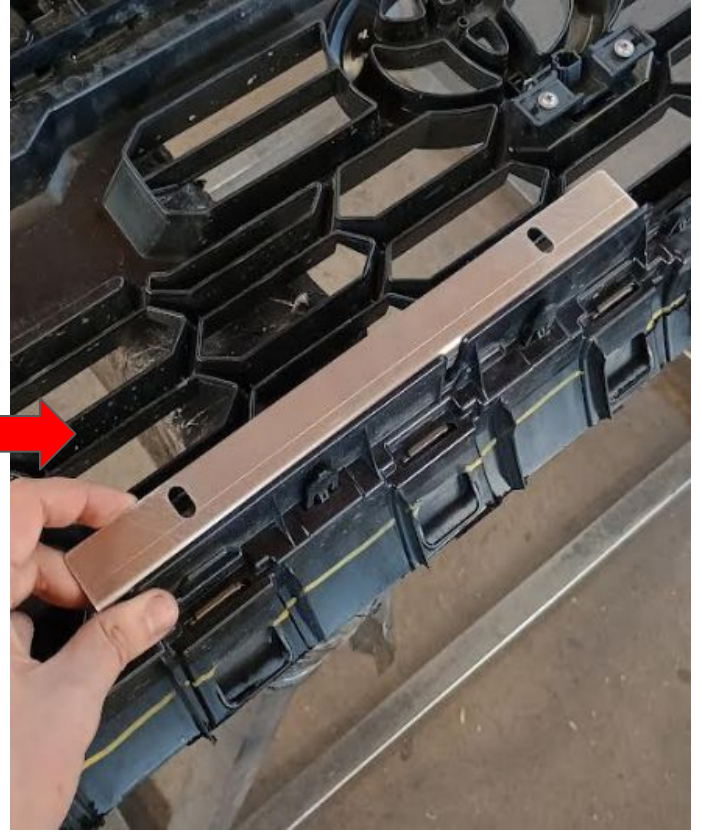

- |                          |    |
|--------------------------|----|
| 1/4" - 20 X 3/4" HEX CAP | 6  |
| 1/4" - 20 NYLOC NUT      | 6  |
| 1/4" WASHER              | 12 |

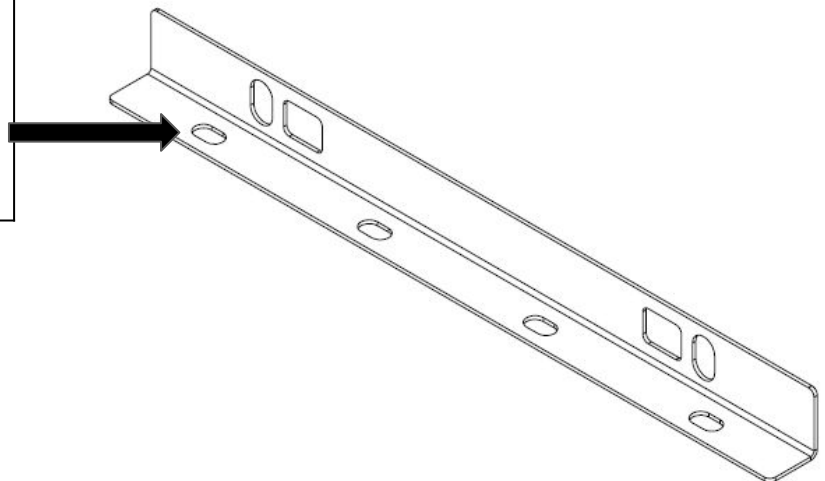

Attach the provided 1/4" clipnut hardware to the other side of the bracket and mount in the section below.

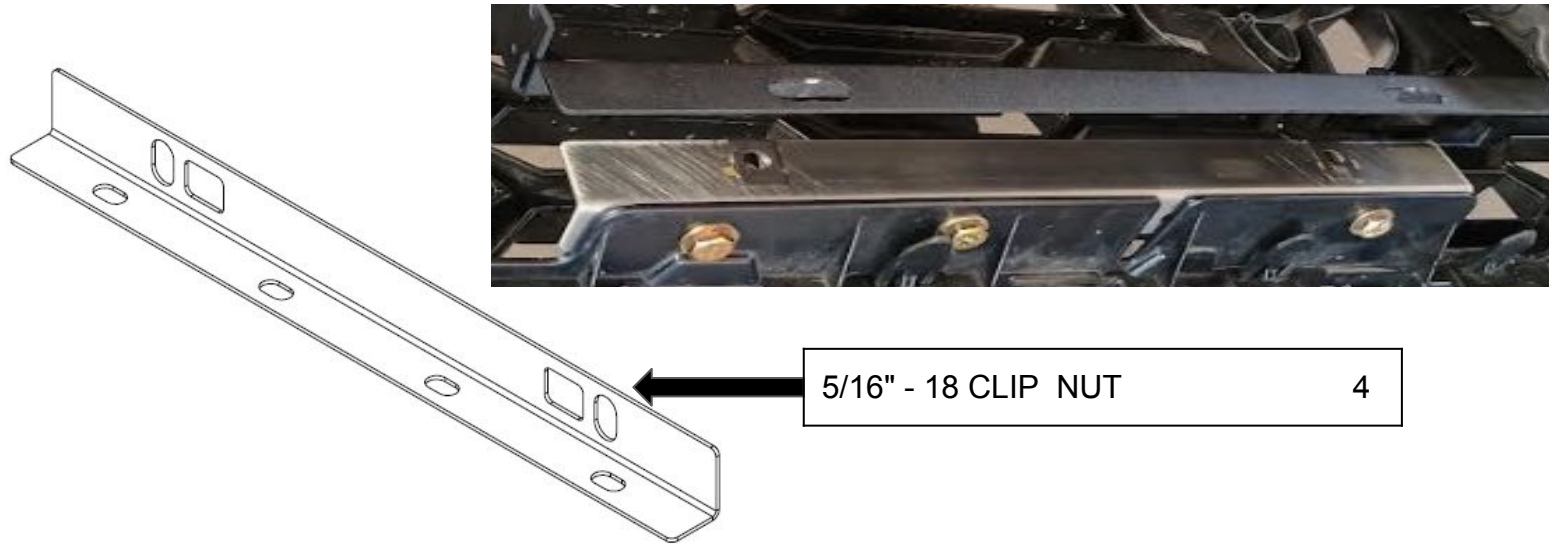

Reinstall the front camera, wiring loom and grille shutter assembly and mount in place. Attach as small L-brackets as shown. Check that connectors match original locations and that wiring does not interfere with the shutter movement. Adjust as needed.

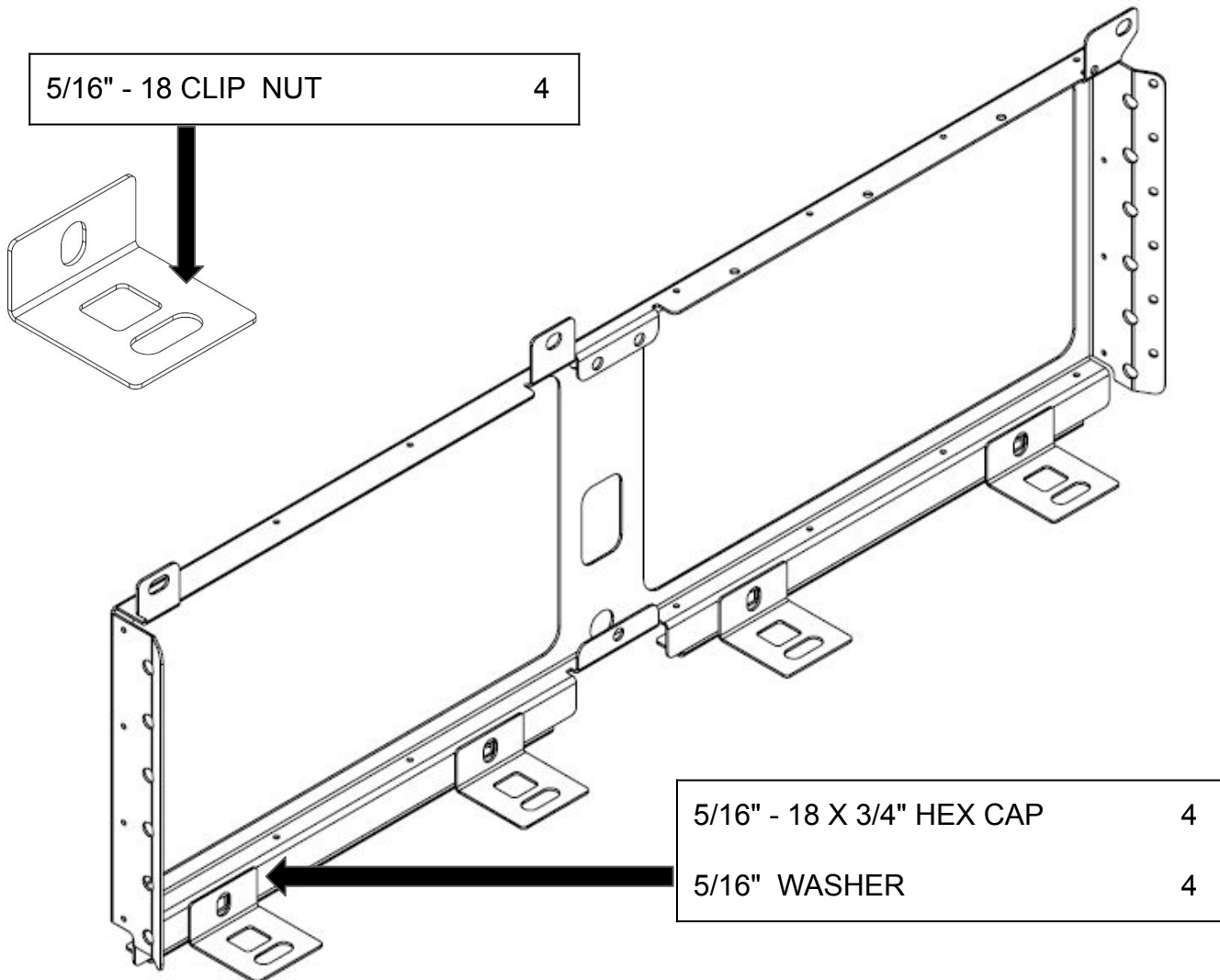



EXAMPLES SHOWN WITHOUT L-BRACKETS

Cut off these tabs to fit new housing



Mount the brackets shown to the cross member using OEM hardware or provided M6's. Adjust and test fit as needed. Once in place remount the OEM bumper back in place. The shutter assembly will then mount the the brackets using

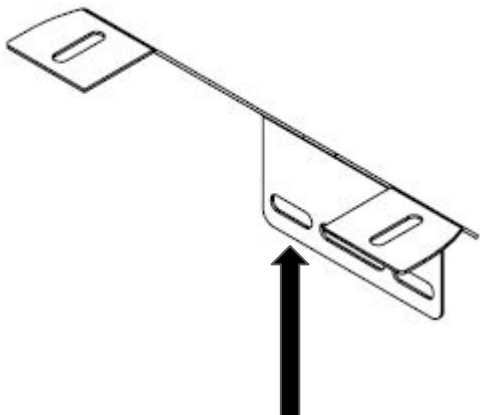

OEM HARDWARE	4
--------------	---

5/16" - 18 X 3/4" HEX CAP	4
5/16" WASHER	4

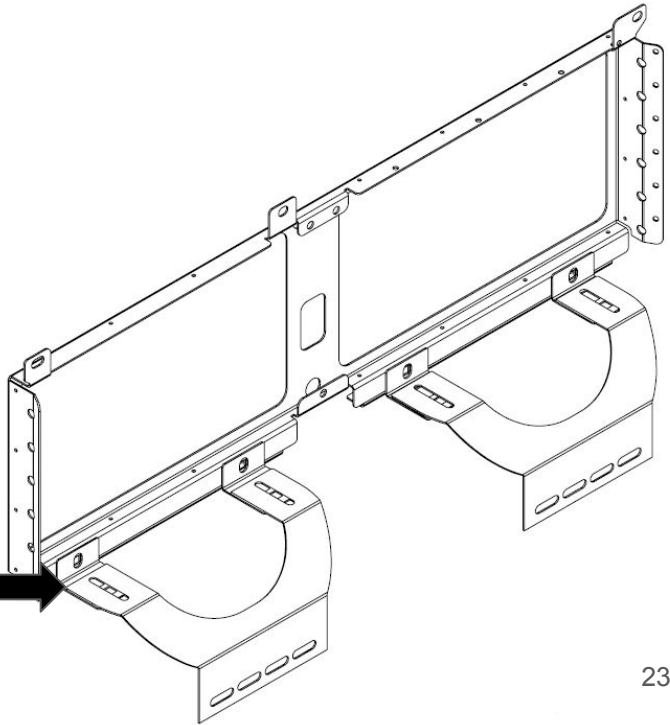

## 9 – OEM LIGHTS INSTALLATION

Mount the OEM lights to the brackets as shown using the provided 1/4" hardware . Attach the bracket using 5/16" hardware. Adjust as needed once on the vehicle.

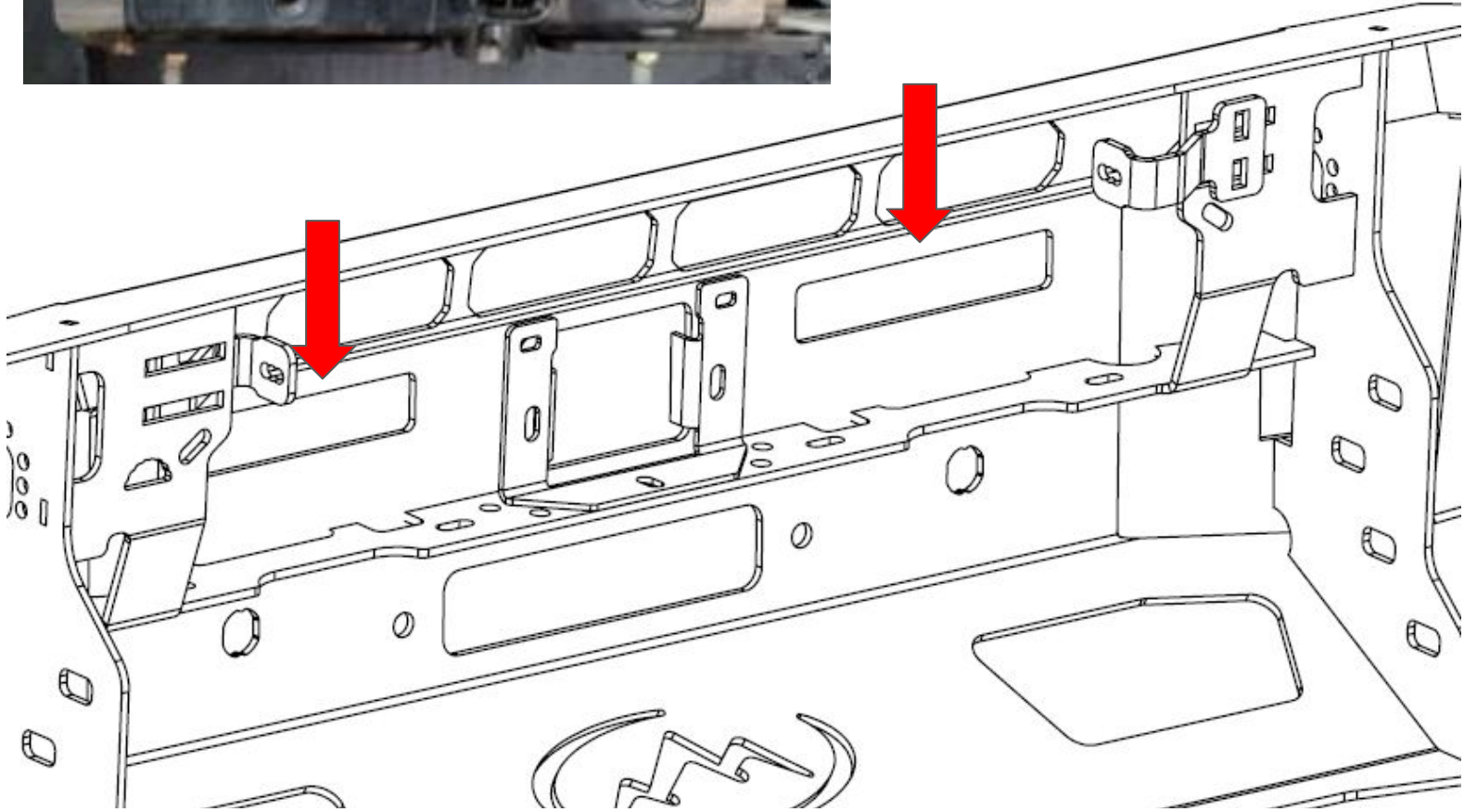

1/4" - 20 X 3/4" HEX CAP	8	→	
1/4" - 20 NYLOC NUT	8		
1/4" WASHER	16		
5/16" - 18 X 1" CARRIAGE	4		
5/16" - 18 NYLOC NUT	4		
5/16" WASHER	4	→	

## 10 – ACC INSTALLATION

Mount the ACC Sensor to the bracket as shown using the provided 1/4" hardware . Place the sensor cover in the bumper and secure in place by attaching the bracket using 5/16" hardware. Adjust as needed once on the vehicle.

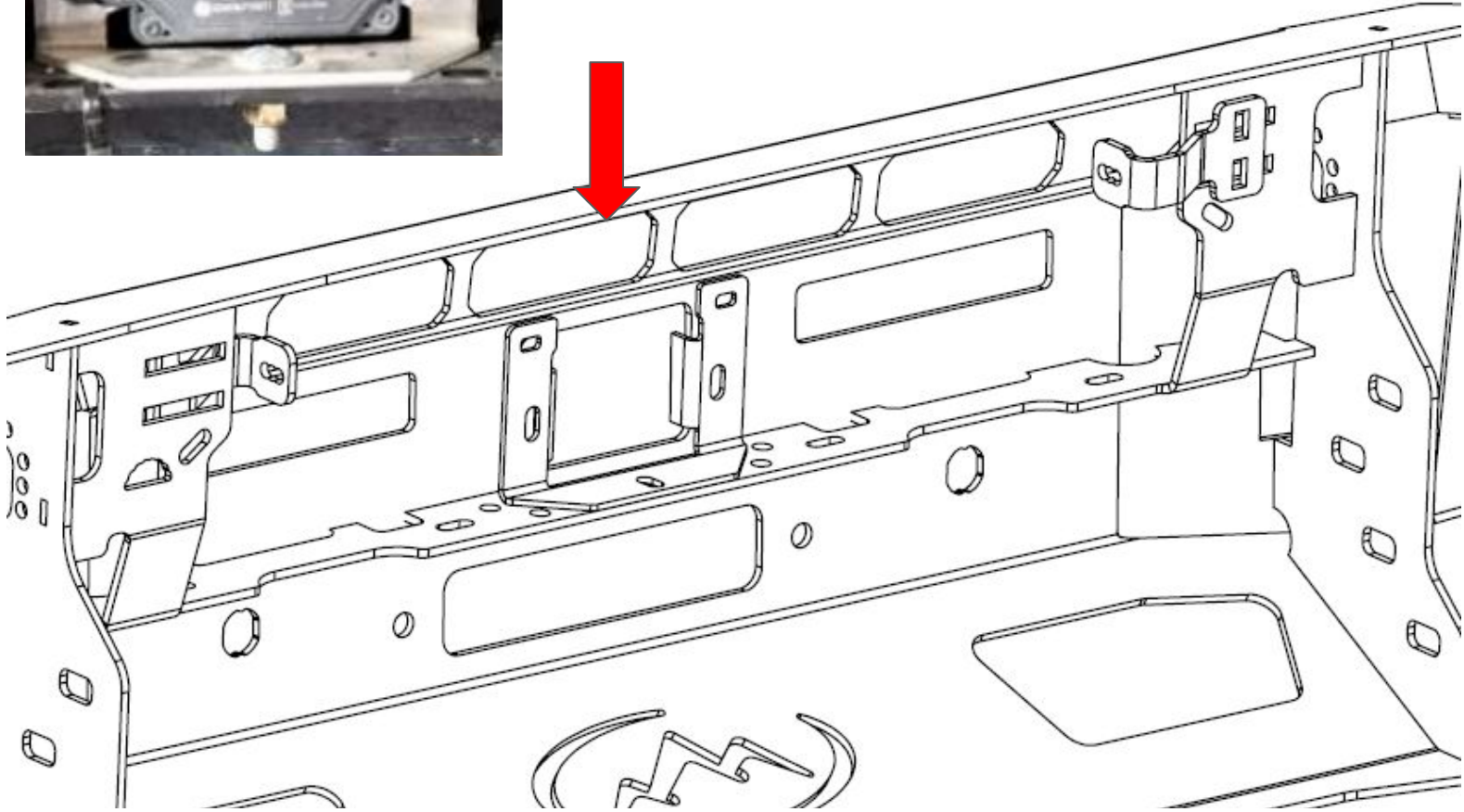

1/4" - 20 X 3/4" HEX CAP

2

1/4" - 20 NYLOC NUT

2

1/4" WASHER

4

5/16" - 18 X 1" CARRIAGE

1

5/16" - 18 NYLOC NUT

1

5/16" WASHER

1

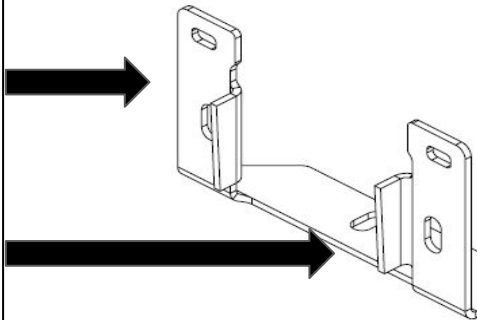

## 11 – LIGHT BAR MOUNTING (OPTIONAL)

Attach the light bar to the brackets using the light bar manufactured supplied hardware. Mount to the bumper using the provided 5/16" hardware.

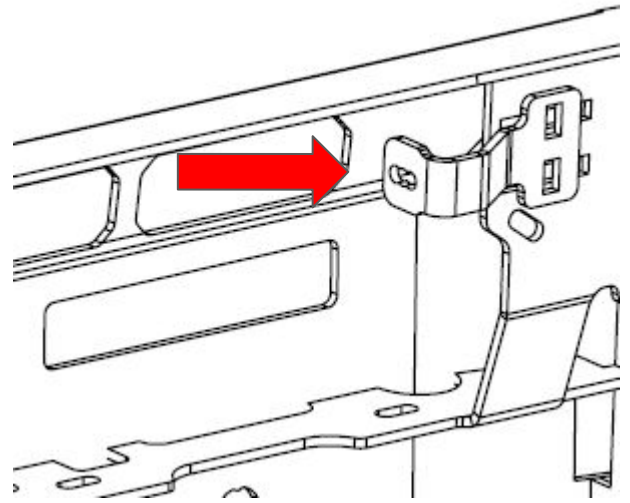

5/16" - 18 X 1" CARRIAGE	4
5/16" - 18 NYLOC NUT	4
5/16" WASHER	4

## 12 – BUMPER MOUNTING

Preposition bumper close enough to weave and reinstall sensors, connectors and wiring. Secure loose wiring and double check for pinch points. Mount the as shown using the provided 1/2" hardware and nut retainers. Adjust as needed and tighten once in place

1/2" - 13 CARRIAGE	6
1/2" - 13 NYLOC NUT	6
1/2" WASHER	6

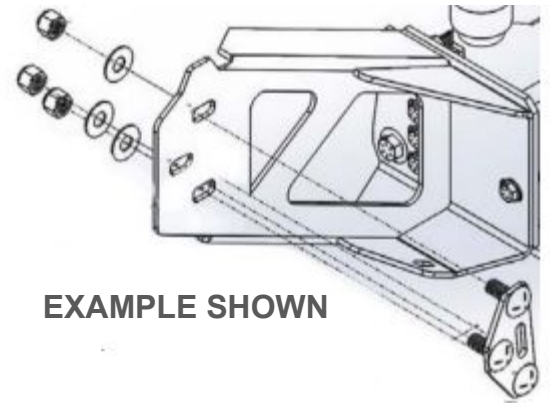

EXAMPLE SHOWN

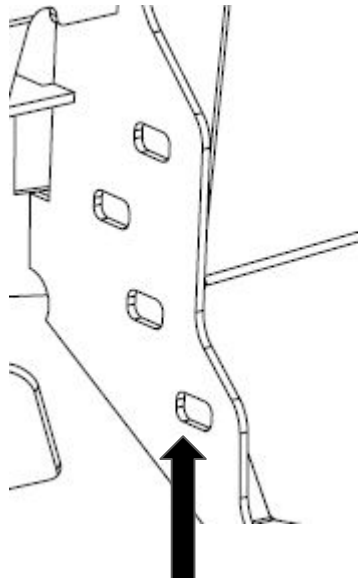
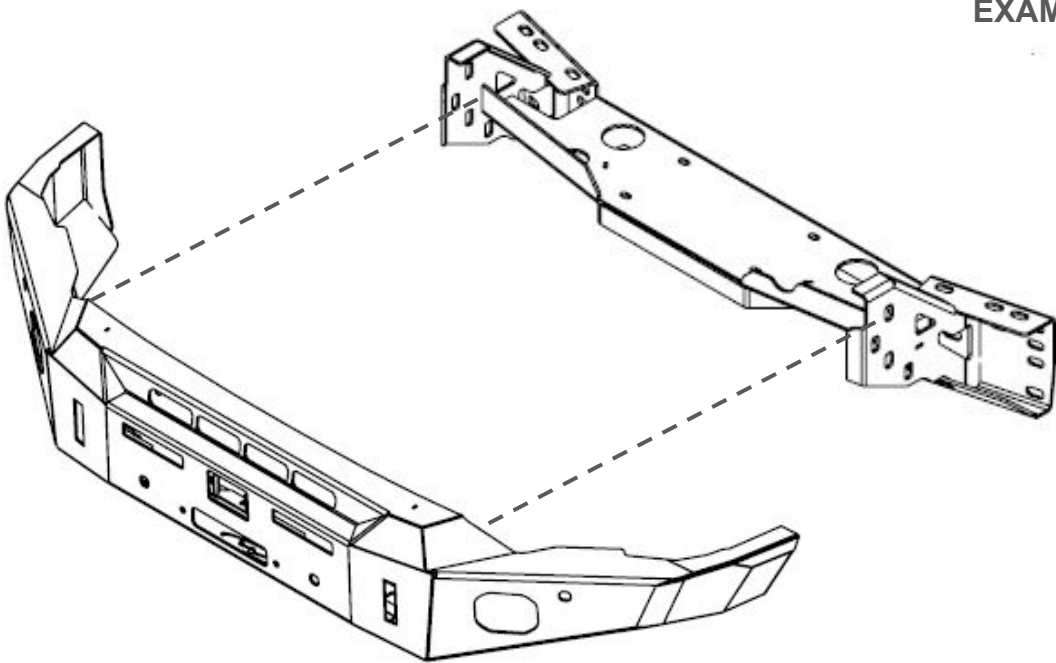

1/2" - 13 X 1-1/4" HEX CAP	2
1/2" - 13 NYLOC NUT	2
1/2" WASHER	4

## 13 – FILLER PLATE MOUNTING

Attach the provided 3/8" clip nuts to the winch mount as shown. Mount the filler plate to the winch mount using 3/8" hardware on top and OEM hardware to the bottom crossmember.

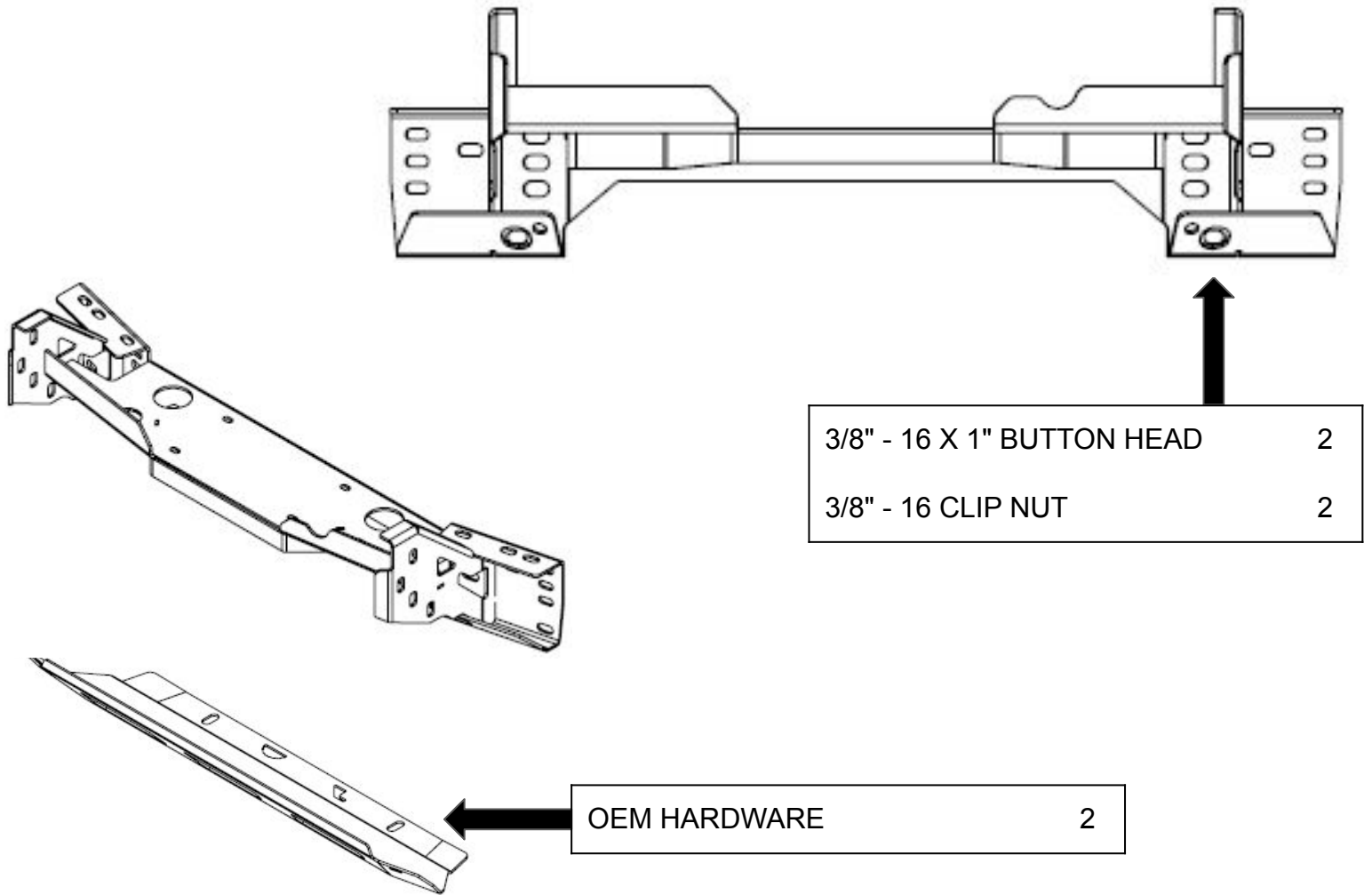

## 14 – TIGHTEN HARDWARE

Check that all hardware is tightened including all brackets and mounting locations. Reconnect the parking sensor wiring harness and other connections to the vehicles electronics and secure all loose wiring. Check that everything is working and adjust if needed before driving on the road.

TIGHTEN ALL HARDWARE AFTER EVERYTHING IS INSTALLED ON THE VEHICLE. CHECK AND RETIGHTEN ALL HARDWARE AFTER THE FIRST 100 MILES AND AFTER OFF ROADING. CHECK REGULARLY AFTER EXTENDED OFFROAD USE

# OPTIONAL PURCHASE PARTS - SKID PLATE

## SKID PLATE MOUNTING

Remove any OEM cladding or skids and mount the the under side using the OEM hardware

