



LEXUS GX550 ROCKER GUARDS



PLEASE READ ENTIRE GUIDE BEFORE INSTALLATION

Recommended that you read this entire install guide before installation. Check that all hardware is present before starting or scheduling an install. This guide is supplemental to mechanical knowledge and ability. Anyone not familiar with automotive installation should seek professional installation.

IMPORTANT INFO/FAQ

INSTALLATION HELP

Please review terms and conditions for details

Recommended purchaser review Welcome Guide at time of purchase for details

Care & Maintenance and Install Guides available at www.exp-one.com/resources

We do our best to offer timely assistance with your installation questions however as most of our team members are primarily engaged in the manufacturing process and packaging processes, we do not currently offer a tech for on-demand calls and inquiries. For the more technical installs or installs that are time-sensitive in nature, we would recommend our customers seek out the services of professional shops with experience specific to aftermarket bumpers.. We are happy to make recommendations to you on shops familiar with our products in your area. We do our best to respond to installation questions within 24-48 hours of contact as much as possible. Long-distance problem assessment can be difficult, so photos and videos are often required for us to best assist you. We highly recommend your initial contact regarding installation questions include both close-up and full photos, detailed descriptions using our part descriptions as much as possible, and video. This enables us to better assist without having the ability to see the install difficulties directly and assist you as quickly as possible.

NOTE

Expedition One does not guarantee fitment with other aftermarket products, or reinstallation of take off OEM parts.

Expedition One is NOT RESPONSIBLE for damage to paint or powder coating, items assembled in error during installation or costs associated with install, and injury.

OEM manufacture model refreshes/updates, factory build location and suppliers may cause variations in fitment or installation and can not be verified, vehicle to vehicle .

EXPEDITION ONE
113 N. 700 W. BUILDING 5C BAY 1
OGDEN, UT 84404
INFO@EXPEDITIONONE.BIZ
801-627-2921 MON-FRI 0900-1700 MST

INSTALL LEVEL



- | | | |
|---------|-------|--|
| 1 STAR | ★ | EASY - No tools required |
| 2 STARS | ★★ | BASIC - Requires standard tools, basic mechanical knowledge and understanding |
| 3 STARS | ★★★ | MODERATE - Requires standard tools. Some drilling and/or cutting. |
| 4 STARS | ★★★★ | ADVANCED - Requires speciality tools. Drilling, cutting, and grinding required |
| 5 STARS | ★★★★★ | EXPERT - Professional installation recommended. |

We always recommend professional assistance when installing our vehicle products. Always follow safety precautions including the use of safety gear and devices.

IMPORTANT INFO/FAQ

HARDWARE

Please review for details and installation. Figures or data may vary. Leave all accessible hardware loose for installation and tighten all hardware after everything is installed on the vehicle. Check and tighten all hardware after the first 100 miles and/or after off roading.

Some hardware locations do not require being tightened to spec due to there design, location or material attachment (including rubber, plastic, and aluminum). Over tightening may break or damage parts. Torque spec may vary, amounts listed are generic.

HARDWARE		TORQUE SPEC	
SIZE	SOCKET	GR5 / 8.8	GR8 / 10.9
#8	1/4"	X	
#10	5/16"		
1/4"	7/16"	6-8	9-10
5/16"	1/2"	13-14	18-20
3/8"	9/16"	23-26	33-37
7/16"	5/8"	37-41	52-58
1/2"	3/4"	57-64	80-90
9/16"	13/16"	82-91	115-129
5/8"	15/16"	112-118	159-180
3/4"	1-1/8"	200-223	282-315
1"	36MM	X	
M6	10MM	9-10	13-15
M8	13MM	22-24	32-35
M10	15MM	44-49	64-72
M12	18MM	76-83	112-123
M14	21MM	102-112	165



GRADE 5

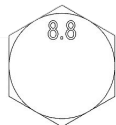



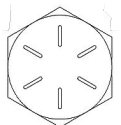



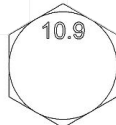







CLASS 8.8



GRADE 8

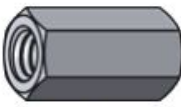

CLASS 10.9

TYPES OF HARDWARE		
		
HEX CAP BOLT	WASHER	NYLOC NUT
		
BUTTON HEAD BOLT	FENDER WASHER	HEX NUT
		
CARRIAGE BOLT	INTERNAL TOOTH	JAM NUT
		
SOCKET CAP BOLT	CLIP NUT	ACORN NUT
		
FLAT HEAD SCREW	RIVET NUT	COUPLING

NOTE

Extra hardware may be left over due to model or option specific items that may not be required for the install. OEM hardware may vary in style or socket size from shown.

TIGHTEN ALL HARDWARE AFTER EVERYTHING IS INSTALLED ON THE VEHICLE. CHECK AND TIGHTEN ALL HARDWARE AFTER THE FIRST 100 MILES AND AFTER OFF ROADING. CHECK REGULARLY

HARDWARE

1/4" – 20 X 3/4" BUTTON HEADS	40
1/4" – 20 NYLOC NUT	40
5/16" USS WASHER	6
3/8" X 1" DRILL SCREW	8
3/8" USS WASHER	16
M8 X 1.25 - 25 HEX CAP BOLT	6
M10 X 1.25 - 30 HEX CAP BOLT	16

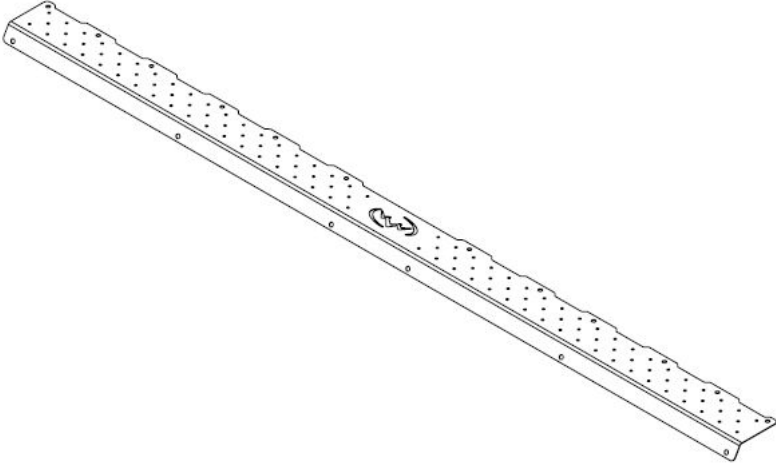
TREAD PLATE	2
	

AFTERMARKET or OEM PRODUCTS

We DO NOT guarantee fitment or installation of any aftermarket, third party or OEM parts, accessories, or hardware. This includes items such as lighting, winches, skids, lifts, suspension, and accessory mounts. Access to all brands, manufactures and country of origin specific parts is limited or impossible during the product development stage and subsequent new or modified revisions of said products including OEM design changes or refreshes. It is recommended you have the product in hand and installed before modifying with other aftermarket parts. Consult other sources to gain any first hand knowledge of other products others have installed.

1 – OEM STEP REMOVAL

If equipped, remove any OEM steps or sliders from the vehicle.

2 – TREAD PLATE INSTALLATION

Install the tread plates on the rocker guards using the provided 1/4" hardware.

(Extra hardware may be left over)

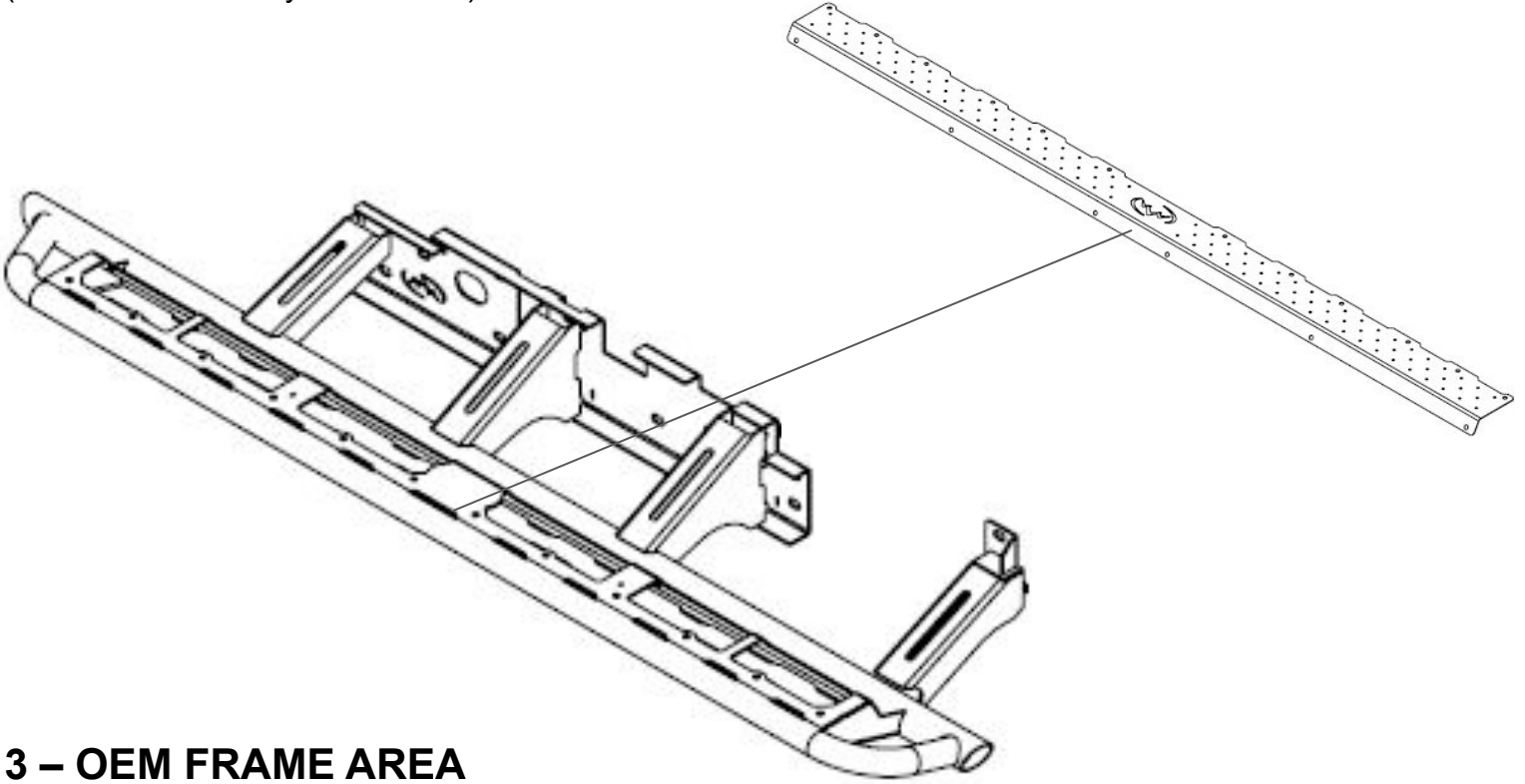

3 – OEM FRAME AREA

Test place the rocker guard in place. Note any locations that have any remaining OEM hardware, bolt on assemblies/parts, or ground wires. Passenger side KDSS area will have to be unbolted . Remove/undo and locations and place out of the way for mounting. Save any hardware for reinstallation after the rocker guards are mounted in place.

4 – ROCKER GUARD INSTALLATION

Mount the rocker guards to the frame and mount using the provided or OEM hardware. Align and adjust as needed before tightening all hardware. Blank locations may be optionally attached to the frame with the provided tap screws if you plan on heavy off road use or crawling. (recommend pre-drilling the frame due to its material strength).

Hardware size or blank locations could possibly vary, check when mounting.

SEE DIAGRAM NEXT PAGE

TIGHTEN ALL HARDWARE AFTER EVERYTHING IS INSTALLED ON THE VEHICLE. CHECK AND RETIGHTEN ALL HARDWARE AFTER THE FIRST 100 MILES OR AFTER OFF ROADING. CHECK REGULARLY AFTER EXTENDED OFFROAD USE